

MSR

Single Roller Dynamometer

Original Operating Instructions

BA053101-en

MSR 500
MSR 800
MSR 830
MSR 850
MSR 1000
MSR 1050

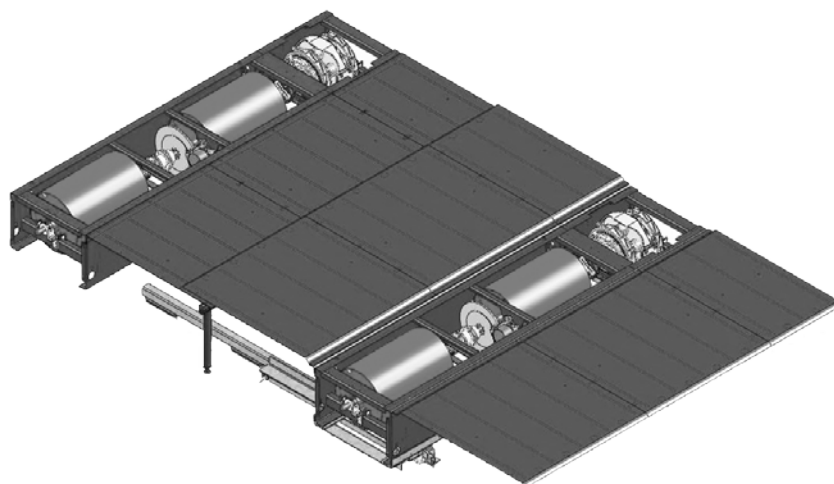

Contents

1	Safety	7
1.1	Introduction.....	7
1.2	Symbols.....	7
1.3	Intended Use	7
1.4	Safety Instructions for Commissioning.....	7
1.5	Safety Instructions for Operation.....	8
1.6	Safety Instructions for Servicing.....	9
1.7	Danger Zone	10
1.8	Safety Information about Tires	10
1.9	Safety Information about the Eddy Current Brake	11
1.10	Safety Features	11
1.11	Accessories	11
1.12	What to Do in the Event of an Accident	11
2	Description	12
2.1	General Information.....	12
2.2	Specifications.....	13
2.2.1	Dimensions	13
2.2.2	Communication Desk.....	15
2.2.3	MSR 500/1	16
2.2.4	MSR 500/2	17
2.2.5	MSR 500/2 4WD.....	18
2.2.6	MSR 500/3 4WD.....	19
2.2.7	MSR 800	20
2.2.8	MSR 830	21
2.2.9	MSR 850	22
2.2.10	MSR 1000	23
2.2.11	MSR 1050	24
2.3	Main Switch	25
2.4	Controls and Indicators	25
2.5	Emergency Stop	26
2.6	Remote Control.....	27
2.7	Description of the Interface Box.....	29
2.7.1	RPM Module (Standard)	31
2.7.2	Environmental Module (Standard)	33
2.7.3	OBD Module (Optional).....	34

2.7.4	Pressure/Temperature Module (Optional).....	34
2.7.5	Analog Input Module (Optional).....	35
2.8	Analog Output Card (Optional).....	35
2.9	Measurement Programs	36
2.10	Calculation Basis.....	37
2.10.1	Road Load.....	37
2.10.2	Torque	38
2.10.3	Extrapolation of the Engine Power with Gasoline Engines	39
2.10.4	Extrapolation of the Engine Power with Diesel Engines (Naturally Aspirated or Supercharged)	40
2.10.5	Extrapolation of the Engine Power with Turbodiesel Engines.....	41
2.10.6	Calculate Engine Factor fm.....	42
2.10.7	4 Wheel Drive Operation.....	43
3	Description of the SINAMICS Components.....	44
3.1	Special Safety Instructions for the SINAMICS Components	44
3.2	Mains Connection for Booksize Drive Assembly.....	45
3.3	Basic Setup	46
4	Transport and Storage	47
5	Installation and Initial Operation.....	47
6	Installation	47
6.1	Requirements for the Place of Installation	47
6.2	Safety Measures	47
6.2.1	Heat Balance	47
6.2.2	Exhaust Suction System.....	49
6.2.3	Fresh Air Supply for the Test Room	50
7	Software.....	51
7.1	System Requirements	51
7.2	Starting the Setup	51
7.3	Selecting the Setup Language.....	52
7.4	Selecting the Destination Folder	53
7.5	Selecting the SQL Server	53
7.6	Selecting the Dyno Type.....	54
7.7	Selecting Features.....	54
7.8	Installing Drivers	55
7.9	Finishing the Setup.....	55
7.10	Additional Settings under Windows 7 or higher.....	56
8	Preparations for Testing.....	59

8.1	Switch on the Dyno	59
8.2	Drive onto Dyno and Secure Vehicle	59
8.3	Connect the RPM Sensor	60
8.4	Connect Oil Temperature Probe	61
8.5	Attach Exhaust Suction System	61
8.6	Position Cooling Air Fan	61
8.7	Bring the Vehicle up to Operating Temperature	62
8.8	Vehicle Ready for Testing	62
8.9	Exit the Dynamometer	62
9	Program Structure	63
9.1	General Information	63
9.2	Tree Model	64
9.3	Screen Design	65
9.3.1	Status Line	65
9.3.2	Main Screen	67
9.3.3	Button Bar	67
9.4	Starting the Program	68
9.5	End Program / Switch off Dyno	68
10	Measurements	69
10.1	Load Simulation	69
10.1.1	Identical Functions	69
10.1.2	Constant Traction	74
10.1.3	Constant Speed	76
10.1.4	Driving Simulation	77
10.1.5	Constant Engine RPM	79
10.1.6	Standstill	79
10.1.7	Drive Dyno	80
10.2	Measure Engine Power	80
10.2.1	Display Last Measurement	80
10.2.2	Continuous Measurement	81
10.2.3	Discrete Measurement	84
10.3	Engine Flexibility Test	86
10.4	Speedometer Check	87
10.4.1	Vehicle Speed	87
10.4.2	Mileage	89
10.5	Load Adaption (Optional)	89
10.5.1	Coefficient Adaption based on ECE	90

10.5.2	Coefficient Adaption based on SAE J2264	91
10.6	Lug-Down Test (Option)	92
11	Settings	93
11.1	Database	93
11.1.1	Identical Functions	93
11.1.2	Performance Curves	96
11.1.3	Time Diagram.....	100
11.1.4	Vehicle Data.....	101
11.1.5	Load simulation profile.....	102
11.1.6	Driving Cycle Data.....	104
11.2	Vehicle Data.....	105
11.3	RPM Setting.....	106
11.3.1	Driving Trial	107
11.4	Special Settings	108
11.5	Select Dyno Type.....	109
11.6	Units	109
11.7	Language.....	110
11.8	Device / Interfaces.....	110
11.8.1	OBd Settings (Optional)	111
12	Diagnosis / Service	112
12.1	Dyno Status	112
12.2	Driver's Aid Setup (Optional).....	112
12.2.1	Test Driving Cycle	113
12.2.2	Edit Profile.....	114
12.2.3	New Profile.....	114
12.2.4	Delete Profile.....	115
12.3	Backup/Restore Database	115
12.3.1	Backup Database	115
12.3.2	Restore Database	115
12.3.3	Delete Table.....	116
12.3.4	Delete Database.....	116
13	Maintenance	117
13.1	Important Information	117
13.2	Annual Inspection.....	117
13.3	Maintenance by the Operator	117
13.3.1	Roller Set	117
13.3.2	Eddy Current Brake.....	117

13.3.3	Bearing Positions	118
13.4	Troubleshooting	118
13.5	Care Instructions	119
13.6	Spare Parts	119
14	Dismantling	119
15	Disposal	119
16	Diagnosis of SINAMICS Components	120
16.1	LEDs after the Control Unit has booted	120
16.2	Smart Line Module 16kW and 36kW	122
16.3	Single Motor Module / Double Motor Module	123
16.4	Sensor Module Cabinet 30 (SMC30)	124
17	Company Information	125

1 Safety

1.1 Introduction

Thoroughly read this manual before operating the equipment and comply with the instructions. Always display the manual in a conspicuous location.

Personal injury and property damage incurred due to non-compliance with these safety instructions are not covered by the product liability regulations.

1.2 Symbols



Important safety instructions. Failure to comply with instructions could result in personal injury or property damage.



Important information.

1.3 Intended Use

This dynamometer is to be used exclusively for the performance testing of motor vehicles. It is not suitable for brake testing or noise detection. Observe the rated axle load.

The equipment may not be modified without the express written consent of the manufacturer. In case of non-compliance the declaration of conformity becomes void.

Any use other than described is inappropriate.

1.4 Safety Instructions for Commissioning

- Only authorized service technicians may install and commission the test stand.
- The test stand may not be installed and operated in fire-endangered operation facilities, outside or in damp rooms (e.g. wash halls).
- Mount components of the vehicle fixing unit in advance on a suitable lift on the test stand.
- Warning stickers must be attached by the operator:
 - Hearing damage due to high noise level. Wear hearing protection.
 - Severe eye injuries due to flying particles. Wear protective goggles! Operator is responsible.
- Wear personal protective clothing as required or as regulated by law. The personal protective clothing must meet the safety-technical regulations for the respective work application.

1.5 Safety Instructions for Operation

- The dynamometer may only be used and operated exclusively for its intended purpose and only within its performance limits.
- The dynamometer may only be operated by trained personnel. Dynamometer and working area must be kept clean.
- The dynamometer may only be operated by persons who are physically and mentally fit. These persons should be well rested and not under the influence of alcohol, drugs or medication.
- When not in use the system must be switched off and the main switch protected against re-start.
- No persons may be in the danger zone of the dynamometer. Rotating or moving parts are dangerous.
- Pay close attention to accident prevention regulations.
- Never climb on roller sets and lifting bar even when locked.
- Avoid unnecessary strain on vehicle and test stand. Drive the vehicle slowly onto the test stand.
- Damage to low lying vehicles is not covered by the warranty.
- Regularly check the tightness of the cover plate attachment screws.
- No persons may be in the pit with dynamometers in conjunction with a working pit while a vehicle with rotating wheels is on the roller set.
- Wear personal protective clothing. If necessary wear protective goggles. Particles ejected from rotating vehicle wheels can cause severe injuries. Wear tightly fitting working clothes and bind long hair together. Clothing or hair can get caught and pulled into machinery.
- Danger of hearing damage due to high noise level! Use hearing protection approved up to 120 dB(A). Noise levels over 110 dB(A) can be reached during vehicle testing. The operator is responsible for determining the noise level in vehicle and test room. When necessary, wear suitable hearing protection. The operator must attach warning stickers.
- Danger of carbon monoxide poisoning by poisonous vehicle exhaust. The test stand may only be operated if the room in which the test stand is installed has sufficient exhaust suction and ventilation including the appropriate warning system.
- Avoid steering movement during the vehicle test. These cause certain forces to act on the vehicle fixing in particular on the attachment units on the test vehicle. Vehicle doors and windows must be closed during the test drive.
- Before exiting the vehicle, put the vehicle into idle and/or put the gear to NEUTRAL. If necessary decelerate the vehicle in a controlled manner avoiding steering movements. Wait until vehicle and rollers have stopped moving before exiting the vehicle. Danger of body parts and clothing being pulled into rotating rollers and vehicle wheels.
- Keep dyno surface clean and dry. Danger of slipping when surface is wet, oily or icy! Do not place any objects (tools, material etc.) on the dynamometer. Wear protective shoes with anti-slip soles and steel toe caps to avoid slipping and mechanical injuries. Parts which protrude more than 20 mm out of the floor are to be marked with black-yellow tape.
- In addition to the danger zone, the operator is responsible for confining the area of the test room in which no persons are allowed during testing with a safety catch device or a cell wall. Mark the danger zone (roller width + 1100 mm) on both sides behind the vehicle up to cell wall/safety catch device.
- Danger of accident due to vehicle fixing fracturing! Do a visual check for damage to the vehicle fixing before each use. Never start the test operation without suitable and correctly installed vehicle fixing. Lower lifting bar before fixing the vehicle. Fix the test vehicle at the back and front side to the dynamometer and secure against lateral break out and swinging movements. The vehicle fixing must be adjusted to the vehicle being tested and may only be used within its stat-

ed purpose and performance limits. Installation of the vehicle fixing exclusively by skilled, trained personell. Inspect attachment units on the test vehicle for strength. Pay attention to manufacturer's information and/or load capacity. Pull on the parking brake and raise the lifting bar before removing the vehicle fixing. The use of unsuitable vehicle fixing, in particular external vehicle fixing increases the danger of injuries and can impair safety.

1.6 Safety Instructions for Servicing

- Service work may only be carried out by authorized service technicians.
- The operating mode selection switch must be put in the correct position with repair, maintenance and set-up work. Remove the key to protect against unauthorized usage.
- The safety devices must be set by authorized service technicians.
- The safety devices may not be replaced or circumvented.
- Wear tight-fitting safety gloves when doing setup work to reduce the danger of pinching. Wear a protective helmet when doing service work in the test stand pit to avoid impact injuries.
- Life-threatening electrical voltage! Only authorized electricians are allowed to work on the electrical parts of the equipment based on valid electro-technical rules and guidelines. Before doing any work on the test stand electricians switch off all voltage and secure against re-starting. Test for absence of voltage! Cabinet contains components with storage charge. After switching off all voltages life-threatening voltage can still be present for at least 5 minutes! Check for discharge before starting work! Lock circuit box and store key securely. Hand out key only if needed to authorized electricians.
- Errors and deviations from normal operating conditions are to be inspected only by trained skilled workers who are authorized to do this kind of work. Circuits which are fed by an uninterruptible power supply are still under voltage even after the test stand has been switched off from the mains connection. The control has circuits which are tapped before the mains disconnection device of the test stand and are not voltage-free after switch off using the mains disconnection. All equipment which are connected before the mains disconnection device are wired with the colors YELLOW or ORANGE. Pay attention to calibration instructions.
- Use suitable lifting device with sufficient load capacity to open heavy test stand components. The heaviest components can weigh up to 300 kg. Removal only by qualified skilled personnel. Adhere to all valid safety regulations and relevant work protection guidelines. Lift test stand components only on the designated lifting points.
- Use suitable lifting device with sufficient load capacity for removal and transport of heavy test stand components. The heaviest components can weigh up to 300 kg. Removal and transport only by qualified skilled personnel. Adhere to all valid safety regulations and relevant work protection guidelines. Lift test stand components only on the designated lifting points.

1.7 Danger Zone

During dynamometer operation no persons are allowed to stay in the danger zone. See illustration for minimum distance.

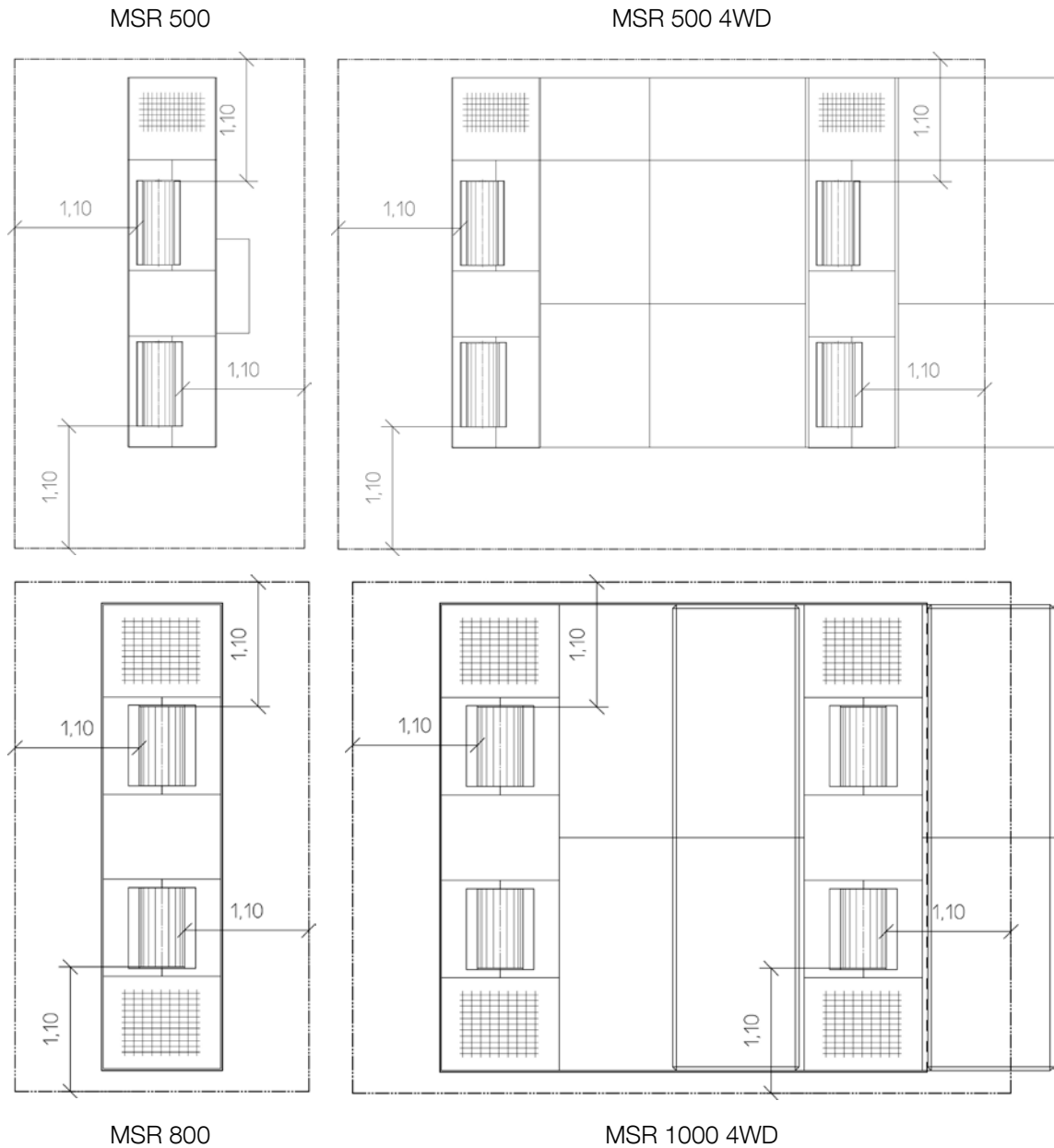

1.8 Safety Information about Tires

- Check tire pressure and do a visual check of the tires for any signs of damage.
- To avoid tire damage we recommend that test tires be used during the performance test.
- No vehicles should be tested which have snow tires, racing tires or retreaded tires!
- Pay attention that the fastest permissible speed for the tires is not exceeded!
- Check the alignment weights on the rims to make sure they are tight before testing.

- Pay attention to tire size! No test should be done with tires under 12”!

1.9 Safety Information about the Eddy Current Brake

The eddy current brake can heat up significantly during long lasting usage. The brake rotors may become red hot.

After a long lasting measurement under load, the eddy current brake should continue to be rotated without load by the vehicle at a speed of approx. 50 – 80 km/h.

The rotating rotors suck cooled air from the side and throw it radially off. The eddy current brake is thereby effectively cooled preventing heat build-up at the rotors damaging the coil insulation.

1.10 Safety Features

The safety features must be checked regularly by an authorized service technician. Pay attention to statutory requirements. The dyno shall not be operated with defective safety features.

Lockable Main Switch

Serves as a normal On and Off switch and as an emergency switch. The switch can be protected against unauthorized usage by locking with a padlock.

Pit Safety (optional)

Light barrier or infrared movement sensor. Issues audible and visual signals in the event that persons are in the working pit.

Warning and Information Labels

Warning and information labels are attached to the dyno. The labels shall not be changed or removed. Defective warning and information labels must be replaced.

1.11 Accessories

The equipment shall be operated only with accessories which have been approved or permitted by MAHA.

1.12 What to Do in the Event of an Accident

- The injured person is to be removed from the danger area. Find out where dressing and bandages are kept. Seek first-aid.
- Provide first-aid (stop bleeding, immobilise injured limbs), report the accident and seal off the accident site.
- Immediately report any accident to your supervisor. Make sure a record is kept of every occasion first-aid is provided, e.g. in an accident book.
- Remain calm and answer any questions that may arise.

2 Description

2.1 General Information

The single roller dynamometer MSR consists of:

- A communication desk with PC, monitor, keyboard and wheel mouse (depending on version)
- A remote control
- One or two roller sets

Optionally available are:

- A cooling air fan which is connected to the communication desk and is operated via the radio remote control.
- An interface box via which the following modules can be connected:

RPM module

Acquisition of engine RPM via Trigger tongs (Otto engine), Piezo clamp sensor (Diesel engine), TDC-sensor (manufacturer-specific, upon request), Diagnostic plug (manufacturer-specific, upon request), Oil temperature probe (up to max. 180°C) and much more.

Environmental module

Acquisition of ambient temperature, intake air temperature, air pressure and humidity, fuel temperature

Analog module

Acquisition of analog signals

OBD module

Acquisition of OBD data

Pressure/Temperature module

Recording of 2 temperatures and 2 pressures each

- To determine performance data of DIN 70020, EWG 80/1269, ISO 1585, SAE J1349 or JIS D1001 a barometer and a humidity sensor are installed in the interface box (Graphic package is prerequisite) (*).
- MAHA emission testers, gasoline (MGT5) and diesel (MDO2 and MDO2 LON) which can be connected to the dyno (*).
- DIN A4 ink jet printer, color (*).
- Fuel consumption device for gasoline and diesel engines. (Krupp/AIC) (*).
- Analog output card to process measured variables as analog signal (e.g. display of issued variables on an external analog instrument (*)).

(*) These options are not connected to the interface box but separately on the dyno.

2.2 Specifications

2.2.1 Dimensions

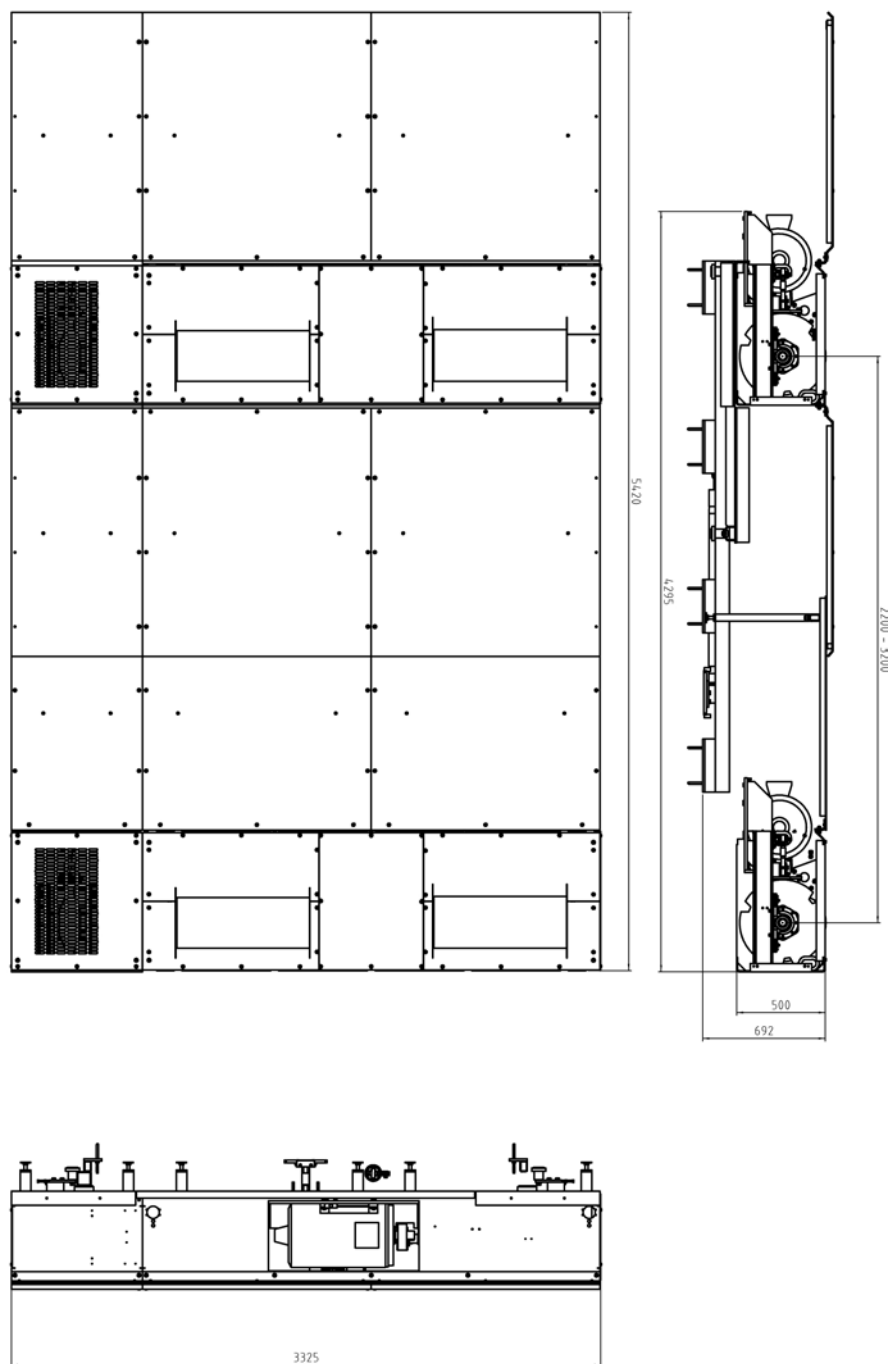

MSR 500

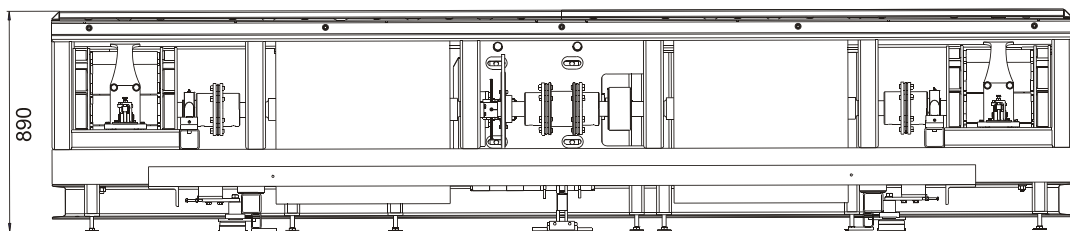
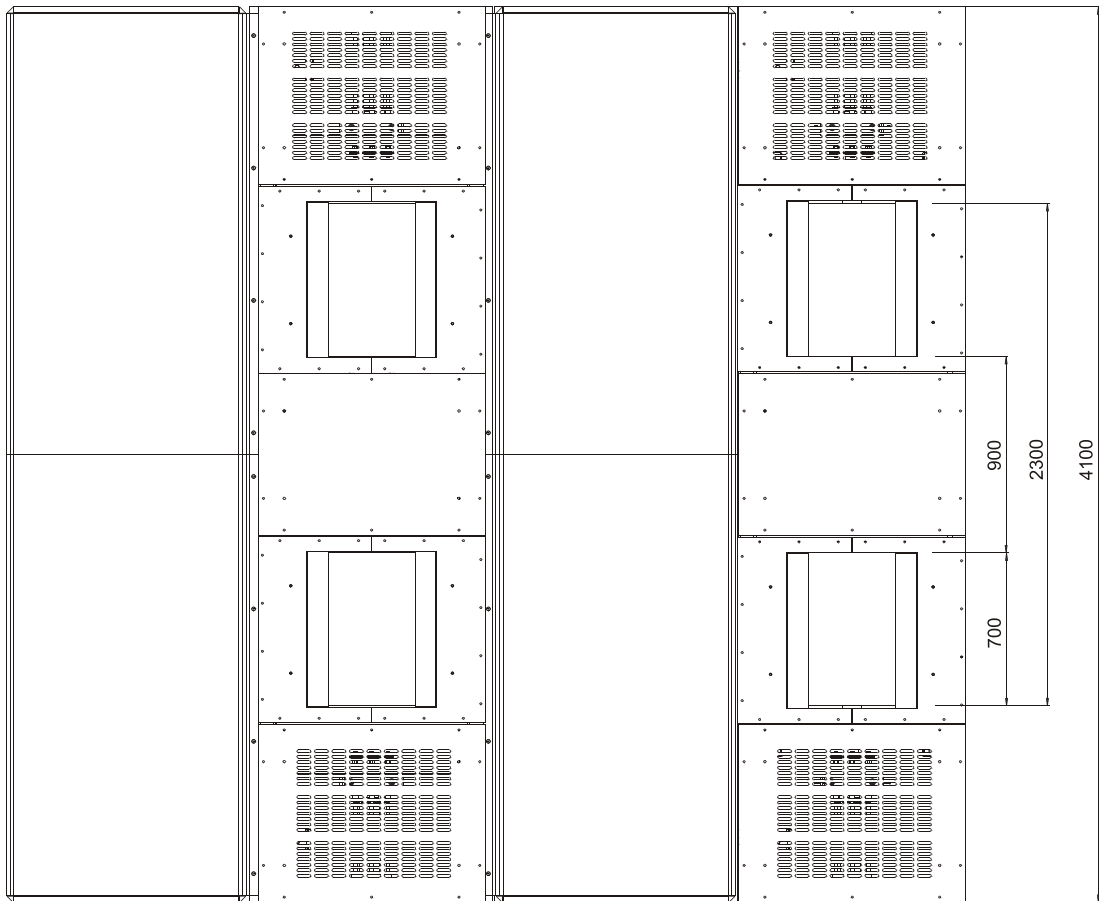
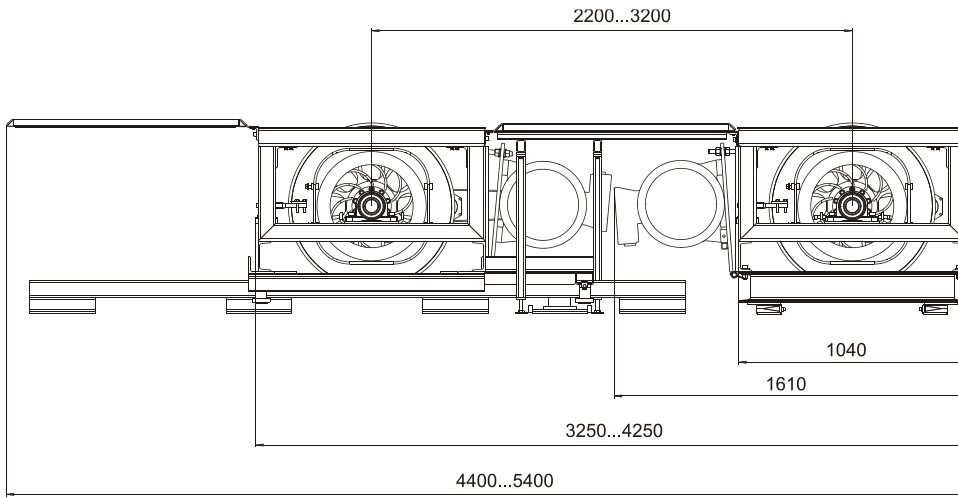

MSR 1000

2.2.2 Communication Desk



Communication desk, Version A	670 x 1400 x 800 mm
Communication desk, Version B (available from March 2011)	350 x 1230 x 860 mm

2.2.3 MSR 500/1

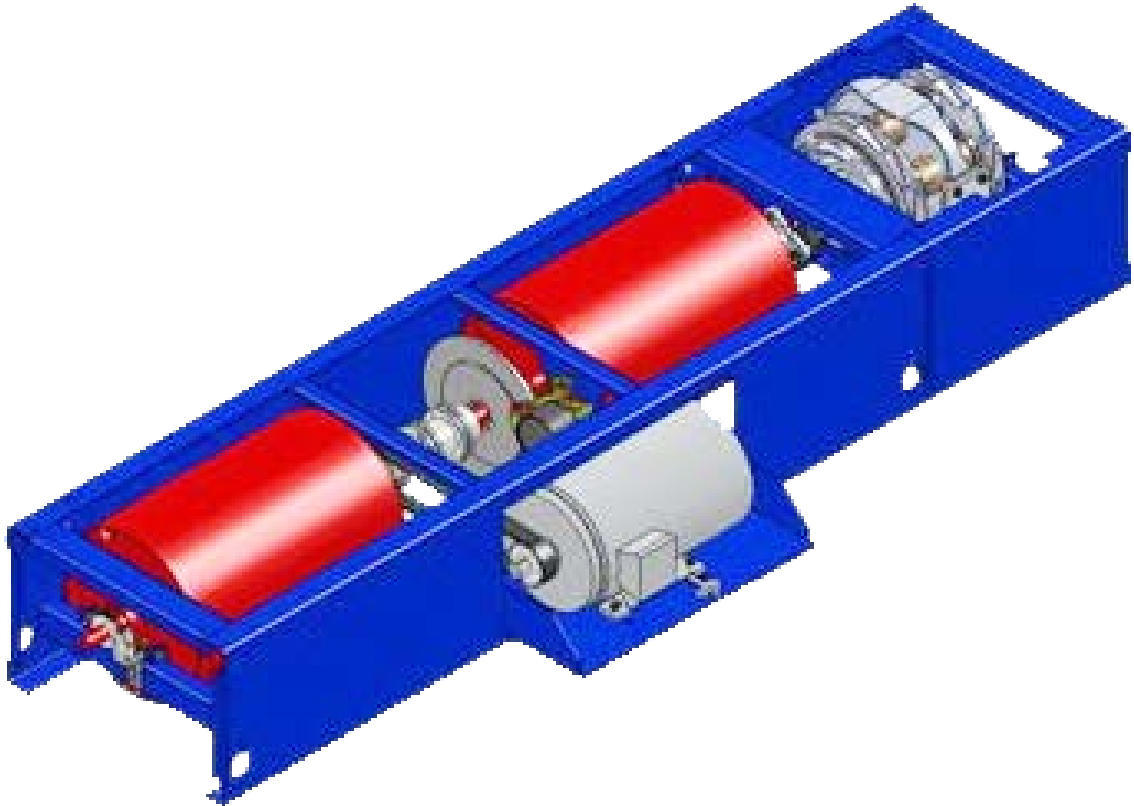
**1-Axle Roller Set with 1 Eddy Current Brake and 1 Electric Motor**

Roller diameter	504 mm / 20"
Rolling circumference	1583 mm
Roller length	750 mm
Track width (min....max.)	700...2200 mm
Roller wall thickness	12 mm
Total weight of Roller set	1630 kg
Mech. inertia weight	approx. 280 kg
Permissible axle load	2500 kg
Maximum speed	300 km/h
Motor power	22 kW
Wheel power stat. / dyn.	260 / 1000 kW
Const. tractive force	7000 N
Fuse with / without drive	63 / 16 A
Supply voltage	3 x 400 + N + PE

2.2.4 MSR 500/2

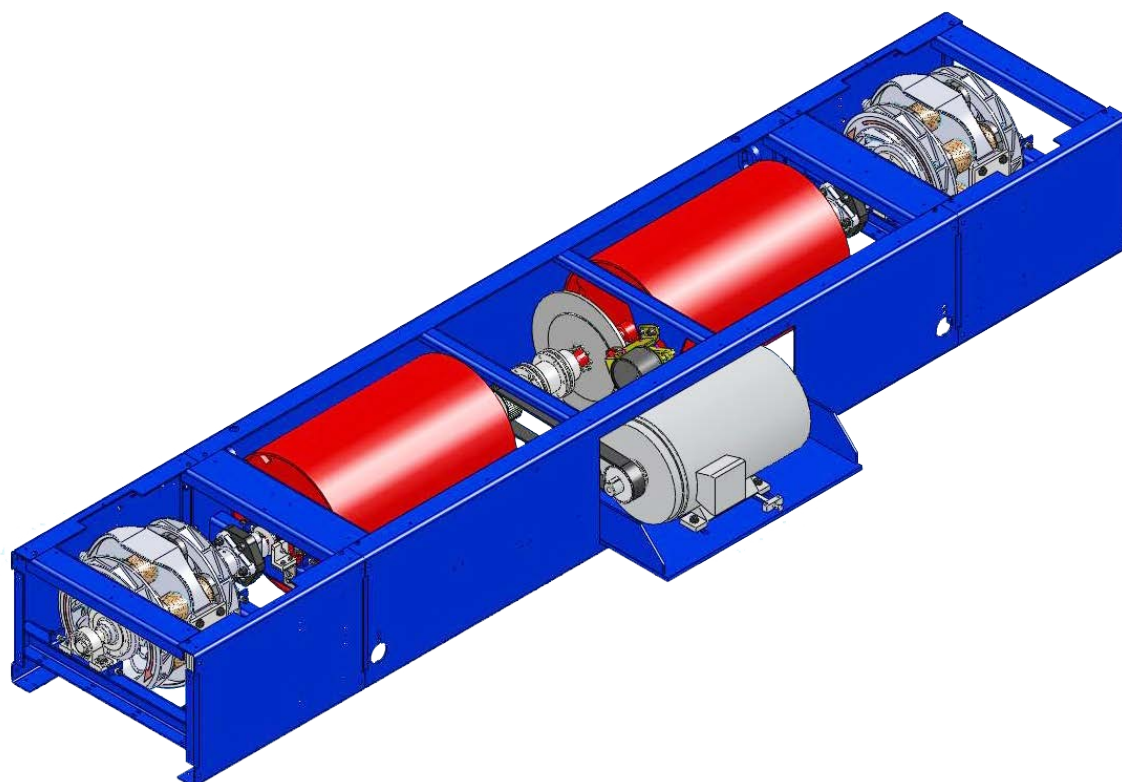

1-Axle Roller Set with 2 Eddy Current Brakes and 1 Electric Motor

Roller diameter	504 mm / 20"
Rolling circumference	1583 mm
Roller length	750 mm
Track width (min....max.)	700...2200 mm
Roller wall thickness	12 mm
Total weight of Roller set	1940 kg
Mech. inertia weight	approx. 305 kg
Permissible axle load	2500 kg
Maximum speed	300 km/h
Motor power	22 kW
Wheel power stat. / dyn.	approx. 520 / 2000 kW (Peak)
Tractive force	approx. 14000 N
Fuse with / without drive	63 / 40 A
Supply voltage	3 x 400 + N + PE

2.2.5 MSR 500/2 4WD

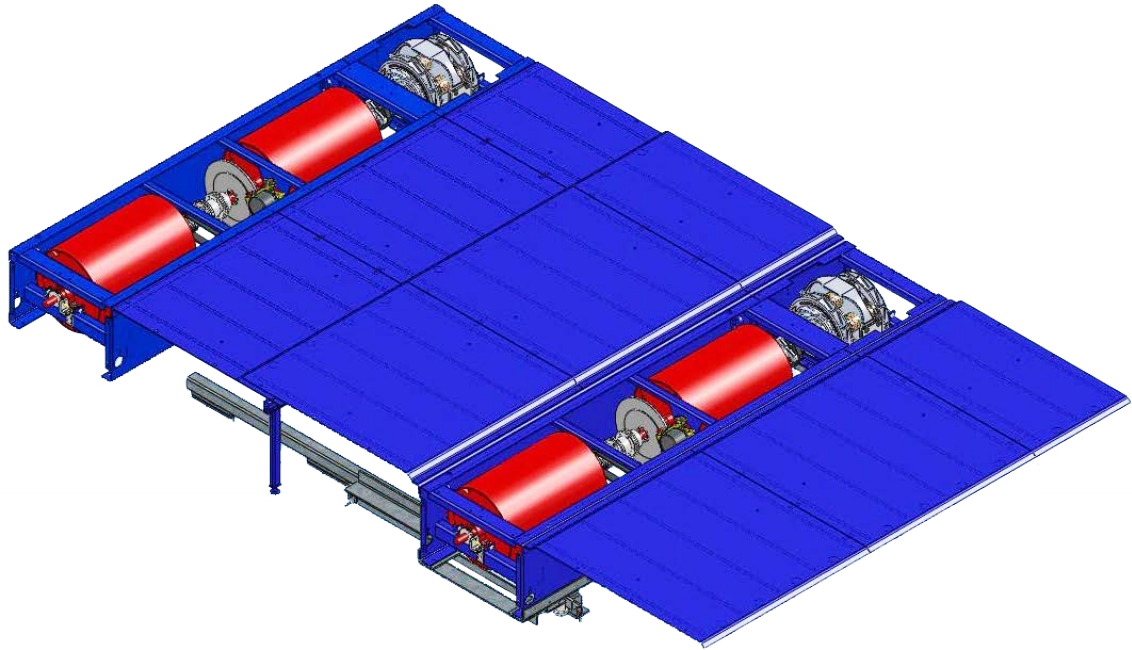
**4WD with 1 Eddy Current Brake and 1 Electric Motor per Axle**

Roller diameter	504 mm / 20"
Rolling circumference	1583 mm
Roller length	750 mm
Track width (min....max.)	700...2200 mm
Roller wall thickness	12 mm
Total weight of Roller set	4130 kg
Mech. inertia weight	2 x 280 kg
Permissible axle load	2500 kg
Maximum speed	300 km/h
Maximum speed of a tracked, non-driven axle	approx. 200 km/h
Motor power	2 x 22 kW
Wheel power Front axle stat. / dyn.	260 / 1000 kW (Peak)
Wheel power Rear axle stat. / dyn.	260 / 1000 kW (Peak)
Tractive force Front axle	approx. 7000 N
Tractive force Front axle	approx. 7000 N
Fuse	63 A
Supply voltage	3 x 400 + N + PE

2.2.6 MSR 500/3 4WD

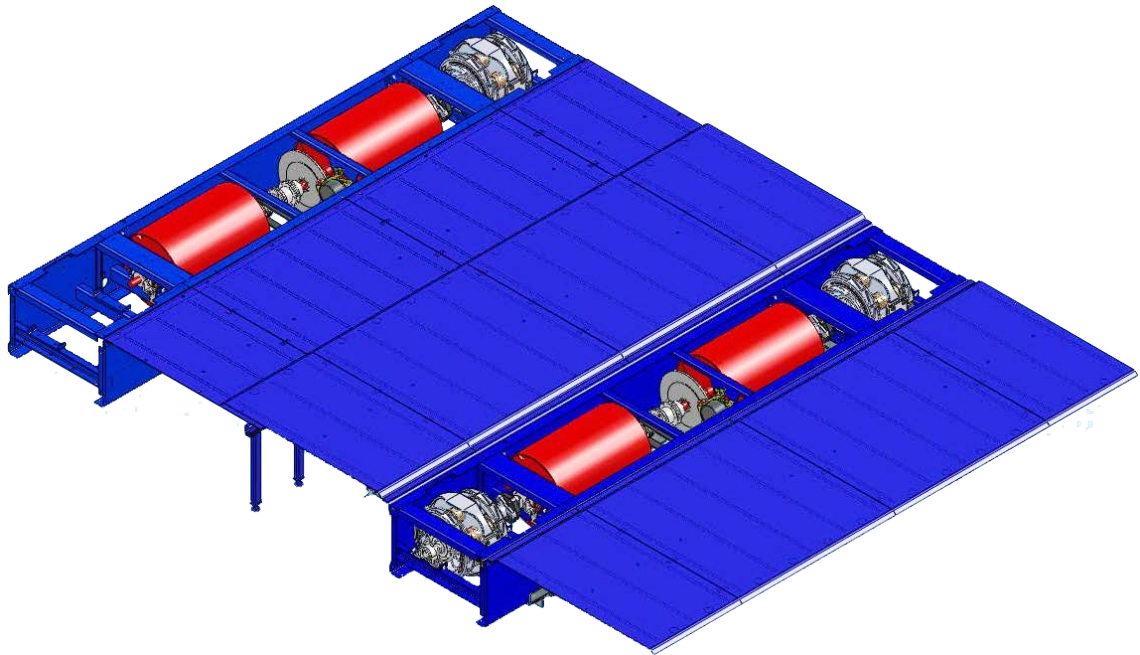
**4WD with 1 Eddy Current Brake FA, 2 Eddy Current Brakes RA, 1 Electric Motor per Axle**

Roller diameter	504 mm / 20"
Rolling circumference	1583 mm
Roller length	750 mm
Track width (min....max.)	700...2200 mm
Roller wall thickness	12 mm
Total weight of Roller set	4395 kg
Mech. inertia weight	1 x 280 kg / 1 x 305 kg
Permissible axle load	2500 kg
Maximum speed	300 km/h
Maximum speed of a tracked, non-driven axle	approx. 200 km/h
Motor power	2 x 22 kW
Wheel power Front axle stat. / dyn.	260 / 1000 kW (Peak)
Wheel power Rear axle stat. / dyn.	520 / 1000 kW (Peak)
Tractive force Front axle	approx. 7000 N
Tractive force Front axle	approx. 14000 N
Fuse	63 A
Supply voltage	3 x 400 + N + PE

2.2.7 MSR 800

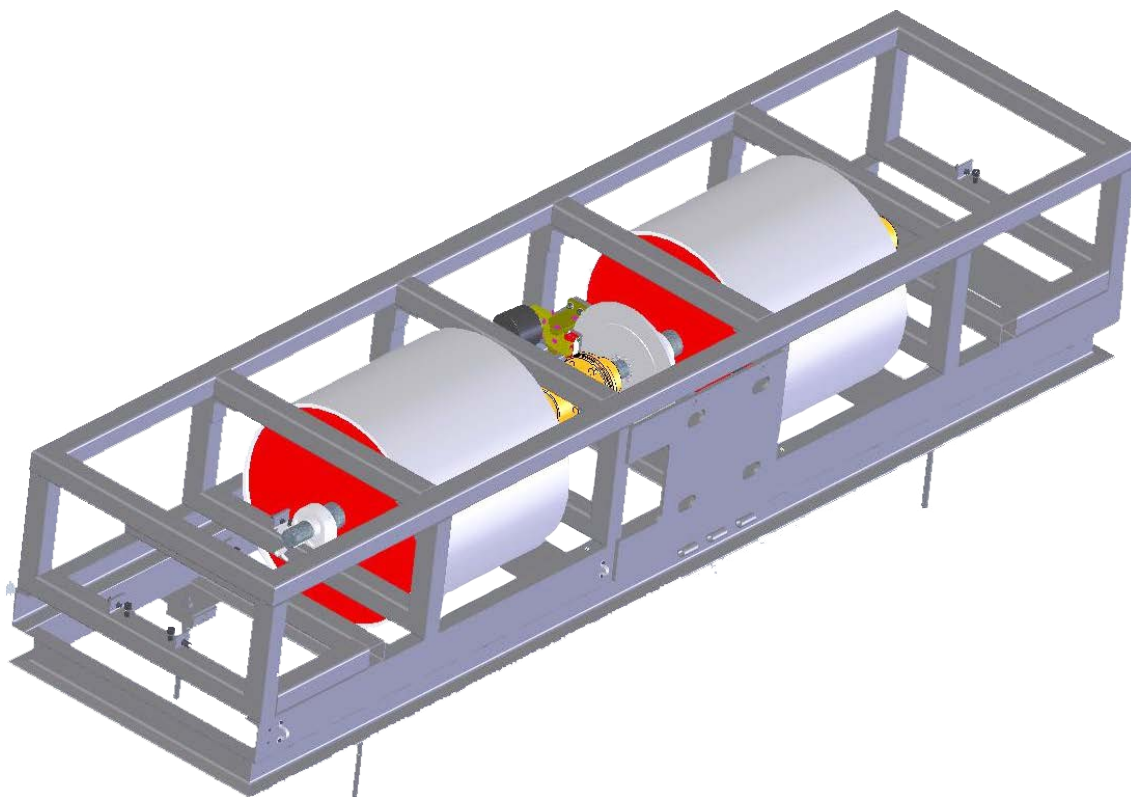
**1-Axle Roller Set**

Roller diameter	762 mm / 30"
Rolling circumference	2393 mm
Roller length	700 mm
Track width (min....max.)	900...2300 mm
Roller wall thickness	20 mm
Total weight of Roller set	1910 kg
Mech. inertia weight	approx. 700 kg
Permissible axle load	2500 kg
Maximum speed	> 300 km/h
Wheel power	approx. 660 kW
Const. tractive force	not available
Fuse	16 A
Supply voltage	230 V + N + PE

2.2.8 MSR 830

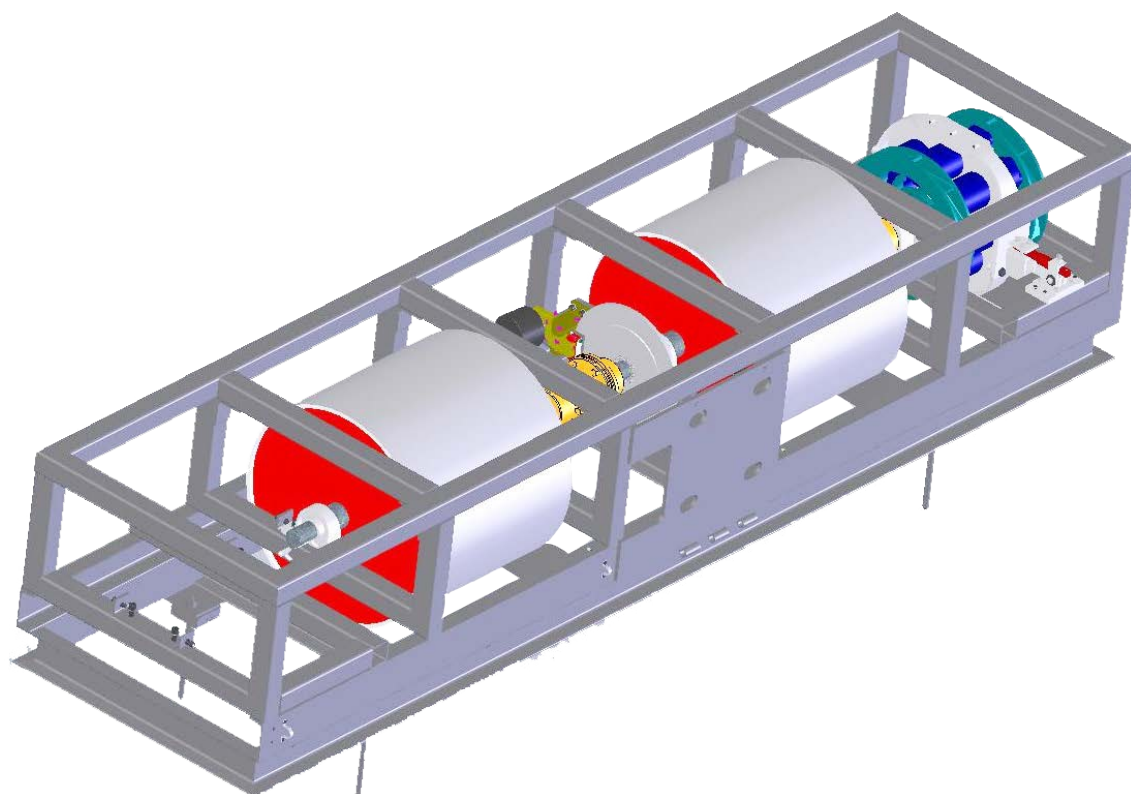
**1-Axle Roller Set with 1 Eddy Current Brake**

Roller diameter	762 mm / 30"
Rolling circumference	2393 mm
Roller length	700 mm
Track width (min....max.)	900...2300 mm
Roller wall thickness	20 mm
Total weight of Roller set	2270 kg
Mech. inertia weight	approx. 700 kg
Permissible axle load	2500 kg
Maximum speed	> 300 km/h
Wheel power	approx. 700 kW (Peak)
Tractive force	approx. 8600 N
Fuse	20 A
Supply voltage	3 x 400 V + N + PE

2.2.9 MSR 850

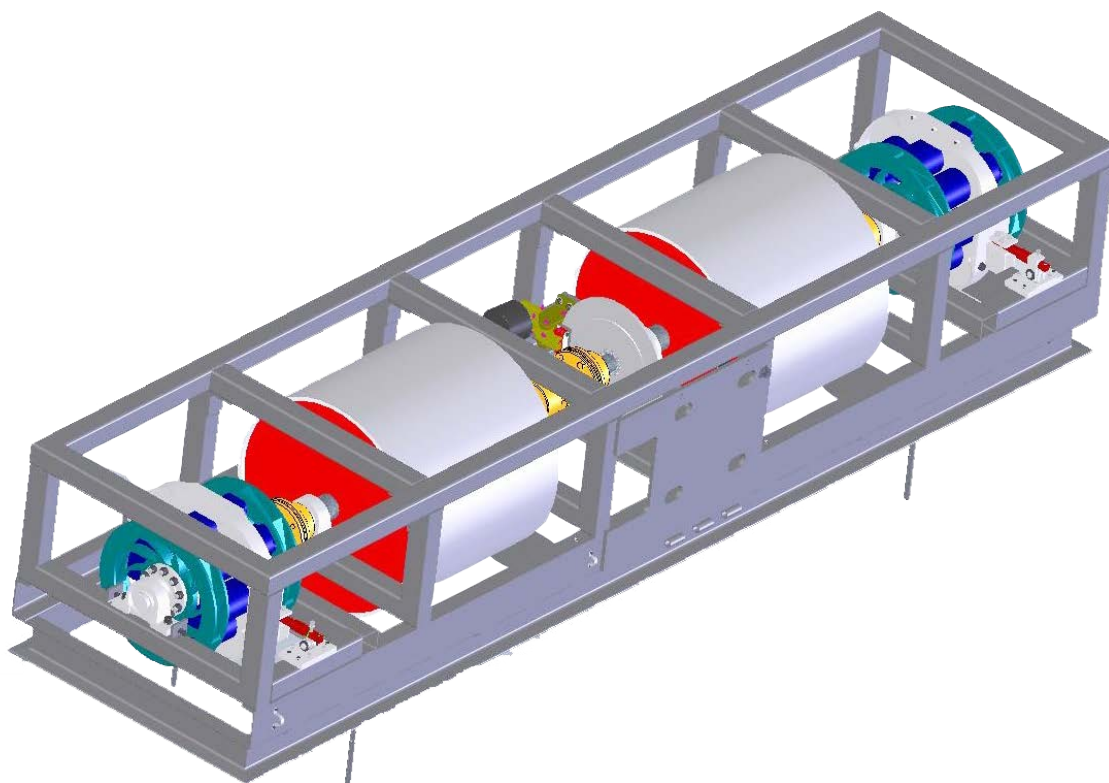
**1-Axle Roller Set with 2 Eddy Current Brakes**

Roller diameter	762 mm / 30"
Rolling circumference	2393 mm
Roller length	700 mm
Track width (min....max.)	900...2300 mm
Roller wall thickness	20 mm
Total weight of Roller set	2630 kg
Mech. inertia weight	approx. 750 kg
Permissible axle load	2500 kg
Maximum speed	> 300 km/h
Wheel power	approx. 1400 kW (Peak)
Tractive force	approx. 17200 N
Fuse	40 A
Supply voltage	3 x 400 V + N + PE

2.2.10 MSR 1000

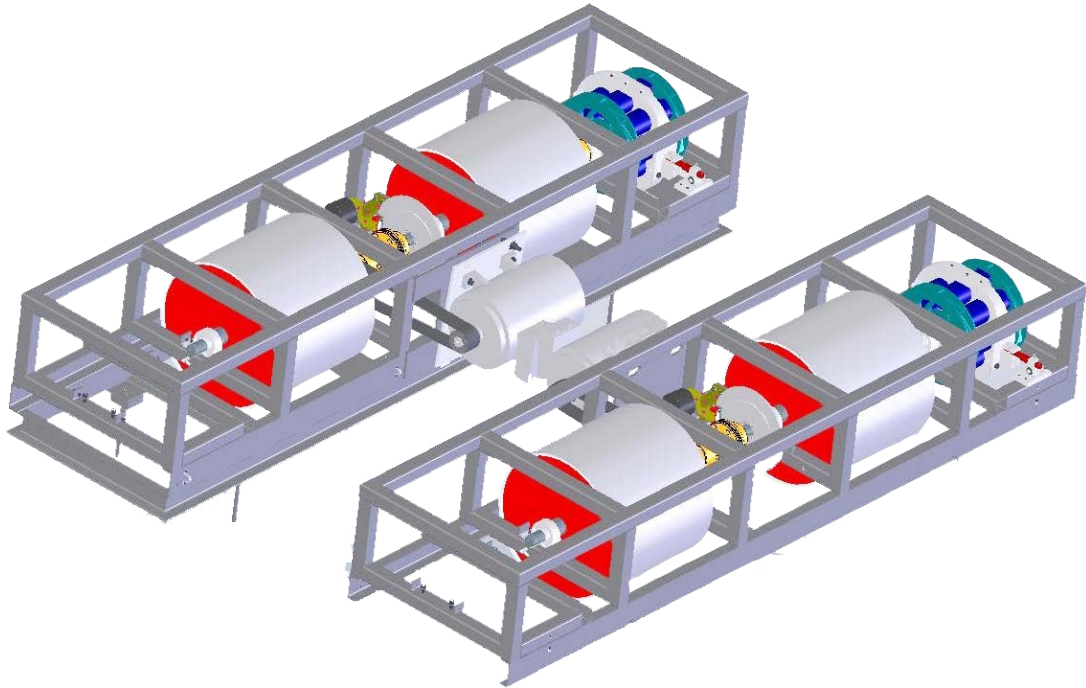
**4WD with 1 Eddy Current Brake and 1 E-Machine per Axle**

Roller diameter	762 mm / 30"
Rolling circumference	2393 mm
Roller length	700 mm
Track width (min....max.)	900...2300 mm
Roller wall thickness	20 mm
Total weight of Roller set	5610 kg
Mech. inertia weight	2 x 700 kg
Permissible axle load	2500 kg
Maximum speed	> 300 km/h
Maximum speed of a tracked, non-driven axle	approx. 200 km/h
Motor power	2 x 30 kW
Wheel power Front axle	approx. 700 kW (Peak)
Wheel power Rear axle	approx. 700 kW (Peak)
Tractive force Front axle	approx. 8600 N
Tractive force Rear axle	approx. 8600 N
Fuse	63 A
Supply voltage	3 x 400 V

2.2.11 MSR 1050

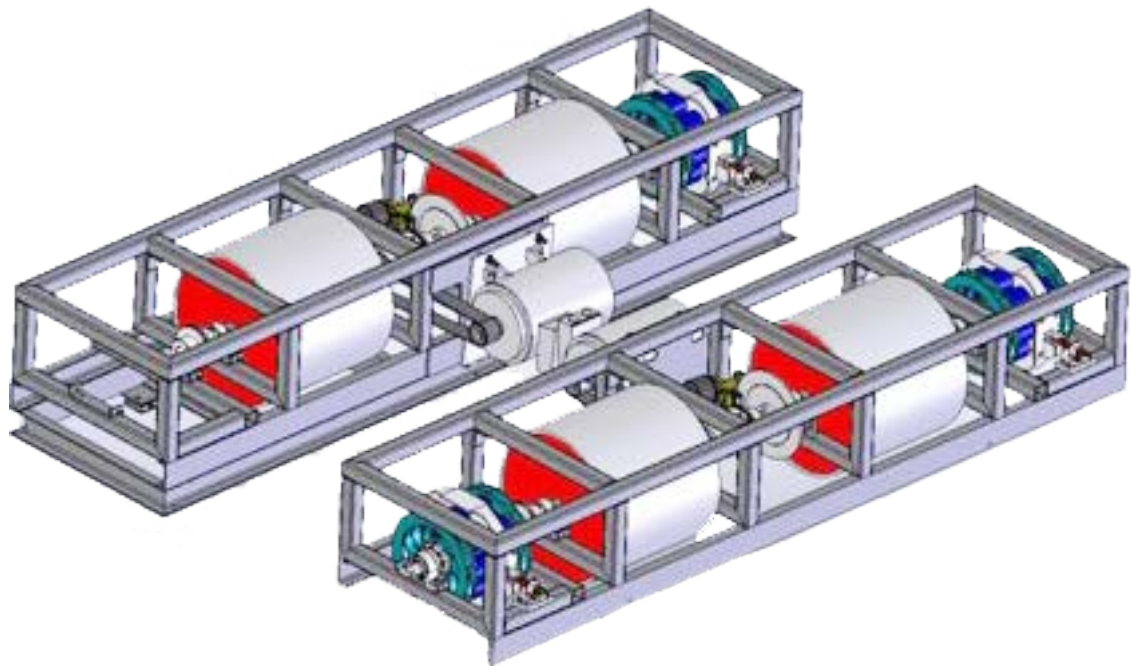
**4WD with 1 Eddy Current Brake FA, 2 Eddy Current Brakes RA, 1 Electric Motor per Axle**

Roller diameter	762 mm / 30"
Rolling circumference	2393 mm
Roller length	700 mm
Track width (min....max.)	900...2300 mm
Roller wall thickness	20 mm
Total weight of Roller set	5970 kg
Mech. inertia weight	1 x approx. 700 kg / 1 x approx. 730 kg
Permissible axle load	2500 kg
Maximum speed	> 300 km/h
Maximum speed of a tracked, non-driven axle	approx. 200 km/h
Motor power	2 x 30 kW
Wheel power Front axle	approx. 700 kW (Peak)
Wheel power Rear axle	approx. 1400 kW (Peak)
Tractive force Front axle	approx. 8600 N
Tractive force Rear axle	approx. 17200 N
Fuse	63 A
Supply voltage	3 x 400 V + N + PE

2.3 Main Switch



The main switch is located at the side wall of the communication desk.

- Main switch in position 0: Power supply OFF
- Main switch in position 1: Power supply ON
- When in position 0, the main switch can be protected against tampering by means of a padlock.

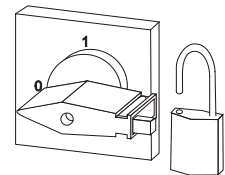

2.4 Controls and Indicators

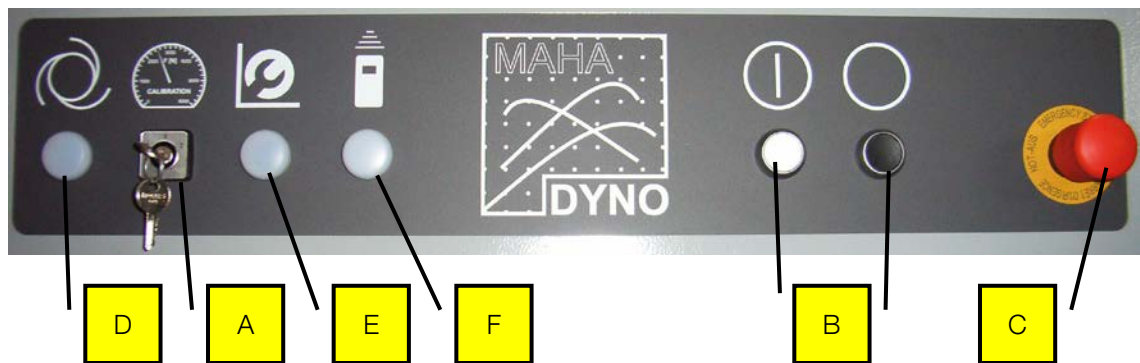

- | | | | |
|---|--------------------------------|---|-------------------------------|
| A | Operating Mode Selector Switch | D | OPERATION Indicator Lamp |
| B | Control ON/OFF | E | SETUP Indicator Lamp |
| C | EMERGENCY STOP | F | REMOTE CONTROL Indicator Lamp |

Operating Modes

	Position 1: OPERATI- ON	Position 0: CALIBRA- TION	Position 2: SETUP
Locking Brake	ON	ON	ON
Hydraulic System	OFF	OFF	ON
Power Section of Eddy Current Brake	ON	OFF	OFF
Motors/Converters	ON	OFF (Safety Stop)	OFF (Safety Stop)



Each time the operating mode is changed, the control is disabled and must be re-enabled using the Control ON button.

Enabling / Disabling the Dynamometer

ON

- 1 Main switch ON.
 - 2 Set operating mode selector switch to required position.
 - 3 Control ON.
- Dyno is ready for operation.

OFF

- 1 Control OFF.
 - 2 Main switch OFF.
- Dyno is shut down.

2.5 Emergency Stop



A EMERGENCY STOP
at Communication Desk

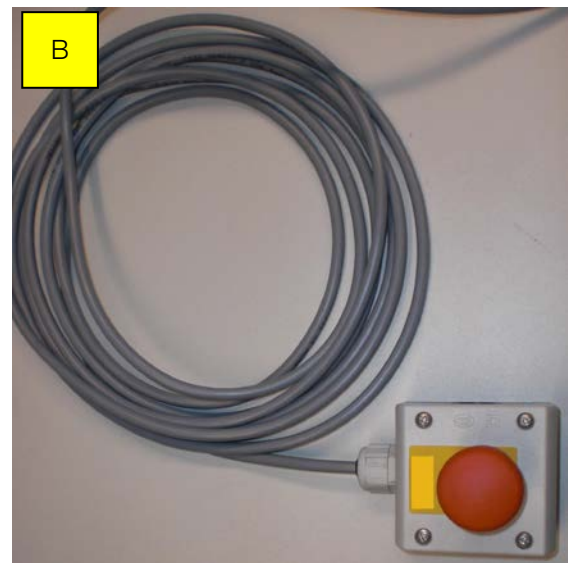

B Portable EMERGENCY STOP
for Motor-Driven Dynamometers

Push the mushroom button to enable the EMERGENCY STOP:

- Motor converters OFF
- Power section of eddy current brake OFF
- All outputs for hydraulic and pneumatic systems OFF
- Program must be restarted

2.6 Remote Control

The functions of the program can also be selected via the remote control. The remote control can be operated directly from the vehicle.

The signal is transmitted by radio. The receiving antenna for the signal is located in the desk.

Should several dynos each with its own remote control be operated in one room, the remote controls must be set to different channels.

As soon as the remote control is switched on and radio connection to the dyno exists, the green control lamp will light up permanently on the operation desk. The green control lamp will blink briefly each time a key is pressed.

When not in use the remote control should always be stored in the re-charging box to avoid a total discharging of the battery. The re-charging box is equipped with a "re-charge overload protection". The re-charging time for a fully discharged battery is about 12 to 14 hours. During the re-charging procedure the red LED on the re-charging box will light up and "Battery recharging" appears on the display of the remote control.

To switch on the remote control press the ON key. The remote control has an automatic switch off (Timeout) which can be variably set. The remote control switches off when no key has been pressed during this time.

The letters on the remote control can be selected by pressing the SHIFT key. Press again to return to the normal operation mode. The display "SHIFT" appears in the window when the SHIFT key has been pressed.

The remote control keyboard consists of two pads: Function key pad + Number pad.

	Remote Control	PC Keyboard
1	Use this key to activate the lifting bar. It can then be operated with the cursor keys.	F3 + Cursor keys
2	Switch fan on / off	F2
3	Deletes an entire line	
4	Selection of a menu item (In combination with the function key F5 and the cursor keys target values can be increased or decreased in some menus.)	
5	Confirmation of inputs	Return
6	Deleting the character before the cursor position Discarding of inputs	Backspace
7	Switch over to letter mode	
8	Connection for Pedal force sensor	
9	In some menus special functions can be opened. The key assignments vary in the different menus. Four boxes with diverse functions are located on the lower screen edge in these menus. These options are selected with the function keys F5 to F8 on the remote control. If the button bar has further levels, these can be displayed using the cursor keys.	F5 to F8
10	Use this key to activate the load simulator. It can then be operated with the cursor keys.	F4 + Cursor keys
11	Use this key to activate the roller set adjustment. It can then be operated with the cursor keys.	

	Remote Control	PC Keyboard
12	Switch on remote control	
13	Exit a program part	
14	Input of a comma	

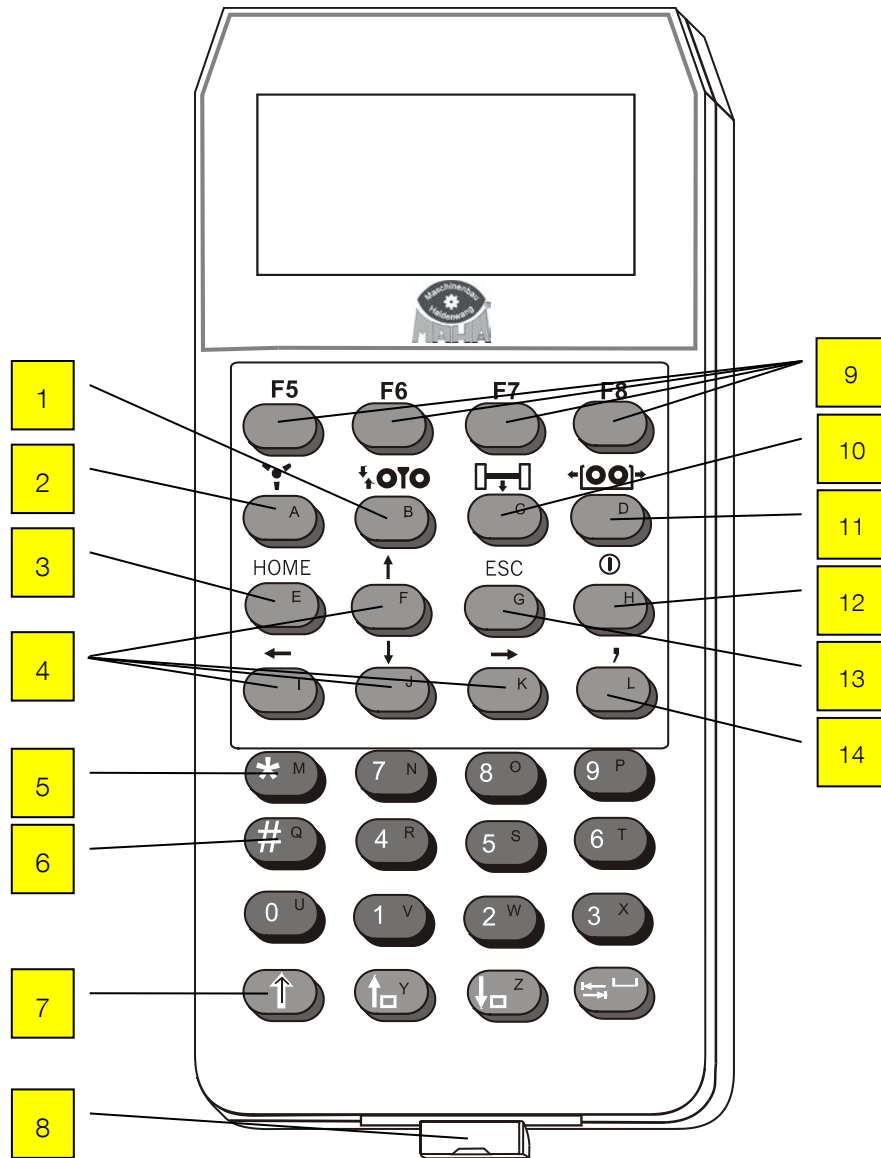

2.7 Description of the Interface Box

The Interface Box records engine RPM, environmental data, OBD data, temperature, pressure and analog signals. This is done via modules. A maximum of 4 modules can be installed in the interface box.

Additional modules can be installed in a second interface box which is connected parallel and, if desired, adapted to customer requirements.



As standard equipment, the interface box 1 has an RPM and an environmental module.

Dimensions (H x W x L)
Weight

approx. 120 x 170 x 160 mm
approx. 1.0 kg

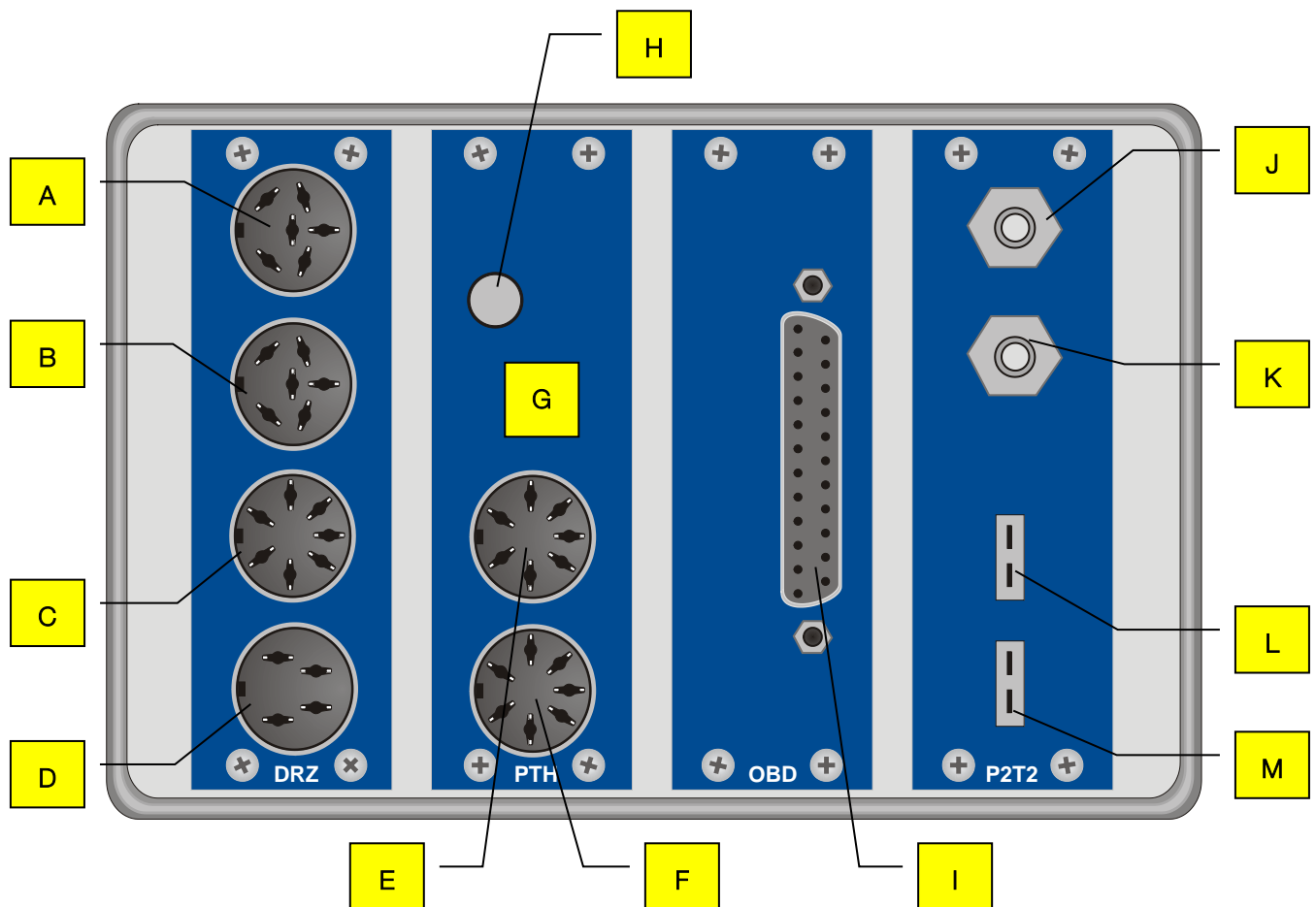

DRZ	A	Piezo clamp, TDC sensor Light barrier
	B	Piezo clamp, TDC sensor Light barrier
	C	Oil temperature probe
	D	Trigger tongs
PTH	E	Fuel temperature
	F	Intake air temperature
	G	Atmospheric pressure
	H	Humidity sensor
OBD (Option)	I	OBD
P2T2 (Option)	J	Pressure 1
	K	Pressure 2
	L	Temperature 1
	M	Temperature 2

Display the Interface Box Assignment

- 1 The assignment of the interface box appears using the keys <SHIFT> + <F1> .
- 2 Use <CONTINUE> or <RETURN> to exit this screen.

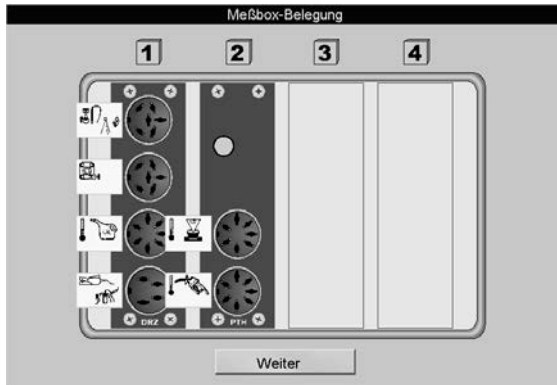

2.7.1 RPM Module (Standard)

The RPM module is used to record the RPM and oil temperature (Plug-in card CAN DRZ).
The following RPM sensors/sources can be used:

Trigger Tongs

The RPM signal is picked up at the ignition cable (spark plug or distributor ignition coil) with the trigger tongs. The trigger tongs should be placed as close as possible to the spark plug and as far as possible from the next ignition cable. The trigger tongs take up the high voltage signal inductively which is conducted from the distributor to any random cylinder. The pulse is relayed from the trigger tongs to the test box where it is converted to an RPM signal.

Attachment:
Position **(D)** on the interface box.



Piezo Clamp

Piezo clamp is only used with diesel engines. The piezo clamp consists of a piezo element which recognizes pressure differences at the lead-in and then converts them into electric pulses. It is important that the piezo clamp which is used is suitable for only one diameter of the fuel line and should only be placed at a straight section of the line at any cylinder (attach ground clamp on the same injection line).

Attachment:
Position **(A)** or **(B)** on the interface box.



Clamp W

The alternator RPM is ascertained through the clamp W. The number of pulses per rotation at the alternator (proportional to the crank shaft RPM) should be known or must be determined by an external measuring device. This is necessary because individual vehicle models have different transmissions between crank shaft and alternator. The RPM determination at the clamp W is only used with diesel engine vehicles.

TDC Sensor

The TDC sensor is always manufacturer-specific, i.e. depending on the vehicle manufacturer the corresponding diagnostic plug is used for the RPM signal pick up.

The TDC sensor offers an extremely accurate RPM measurement.
Once f_{\max} is reached, an RPM of 12000 $\text{rot}/\text{min}^{-1}$ is displayed.

The level must be between 30 mV and 30 V so that an RPM pulse is recognized

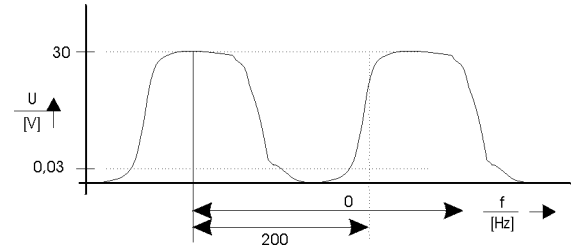

Attachment:

- Position **(A)** or **(B)** on the interface box.

Light Barrier

The light barrier is used when no direct way of determining the RPM at the engine is possible. The transmission ratio to the engine RPM must be 1:1. If the light barrier is attached to the cardan shaft, the transmission ratio must be between 0.5 and 2. The light barrier must be positioned in such a way that via a reflector which is attached either to the vibration absorber, drive belt, or cardan shaft, the RPM can be picked up free of any interference (no vibration influence etc.).

Notes on adjusting the engine rpm via the light barrier

When making adjustments in the lower rpm range (drive shaft rpm < 800), we recommend using **two** reflectors in order to double the number of impulses generated.

When doing so, please remember the following:

- The reflectors must be systematically placed around the engine, exactly opposite one another. Prominent points on the engine housing can be used to position the reflectors.
- When entering the gear ratio you must also double the previous value.



Attachment:

Position **(A)** or **(B)** on the interface box.

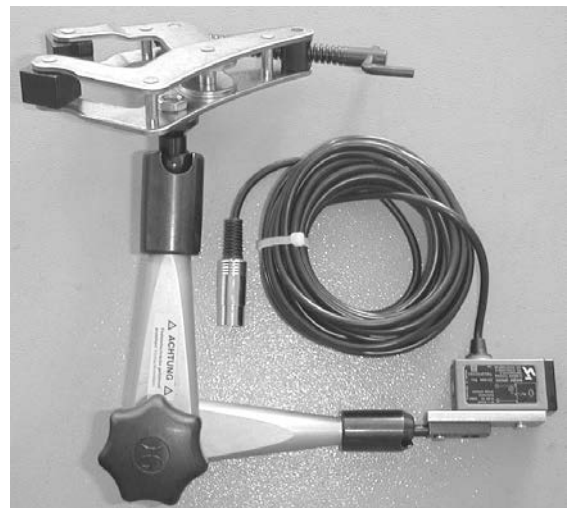

Driving Trial

If none of the above mentioned alternatives is available for determining an RPM measurement, a driving trial can be used to do the same. The RPM is converted from the dyno roller speed.

At the beginning of a test a pre-determined RPM value must be approached ('Test gear' / Gear transmission close to 1:1) while in a specific gear. This RPM value will be stored.

During the performance test the software will convert the roller's current RPM into engine RPM. (Please note: The calculated RPM will only correspond if the vehicle is driven in the 'test gear'.)



Automatic transmission vehicles without converter lockup cannot use the driving trial method, because the engine RPM deviates due to converter slip.

OBD Module

The RPM is read from the OBD data.

Oil Temperature Probe (Optional)

Driving trials should only be done when the engine is warmed up to operational temperature. The oil temperature meter is used to determine the oil temperature and to monitor it during the testing procedure.

Oil temperature probe for car and truck, with variable length (100 to 1500 mm), with plug and 6 m supply line.

Attachment:

Position (C) on the interface box.

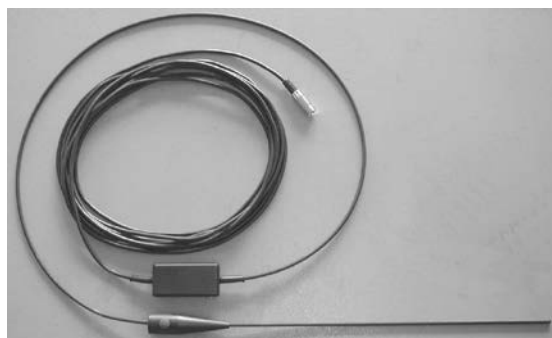

2.7.2 Environmental Module (Standard)

The environmental module is used to record the environmental data (Plug-in card CAN PTH).

- Fuel temperature (Optional)
- Intake air temperature
- Ambient temperature
- Air pressure
- Humidity

Fuel Temperature (Optional)

The fuel temperature is recorded using the interface box and the fuel consumption device and can be used as additional information for the fuel consumption measurement.

Intake Air Temperature

The intake air temperature is recorded using the interface box and is used for projection of the engine performance based on DIN 70020, EWG 80/1269, ISO 1585, SAE J1349 or JIS D1001.

Ambient Temperature

The ambient temperature is recorded using the interface box.

Air Pressure

The air pressure is recorded using the interface box and is used for projection of the engine performance based on DIN 70020, EWG 80/1269, ISO 1585, SAE J1349 or JIS D1001.

Humidity

The humidity is recorded using the interface box and is used for projection of the engine performance based on DIN 70020, EWG 80/1269, ISO 1585, SAE J1349 or JIS D1001.



The current air temperature, ambient pressure and relative humidity is included in the calculation with the given standards (DIN 70020, EWG 80/1269, ISO 1585, SAE J1349 and JIS D1001)

2.7.3 OBD Module (Optional)

The OBD module is used for recording the OBD data (Plug-in card CAN OBD Module). This OBD data is different depending on the vehicle manufacturer.

Attachment:

- Position (**OBD**) on the interface box (see section "*Description of the Interface Box*").

**2.7.4 Pressure/Temperature Module (Optional)**

The pressure/temperature module is used to record 2 temperatures and 2 pressures (Plug-in card CAN P2T2).

Pressure 1 + 2

Pressure 1 +2 is user specific. The test range stretches from - 0.9 to + 4.0 bar and can for example be used to determine the intake pressure, turbocharger pressure, etc.

Exhaust Gas Temperature

The exhaust gas temperature is used as monitor check of the combustion process and to judge its quality.

The high temperature sensor consists. of a Ni-Cr-Ni thermo element with compensation line.

The measurement range stretches from 0 to 1000 °C.

2.7.5 Analog Input Module (Optional)

The analog input module is used to record 4 analog signals (Plug-in card CAN AIN4). Measurement data from -10 V to $+10\text{ V}$ or from -20 mA to $+20\text{ mA}$ can be recorded.

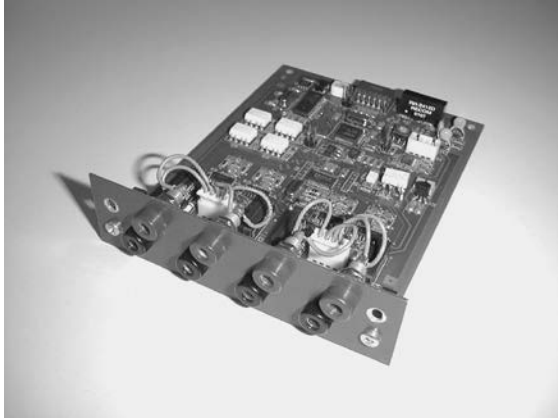

2.8 Analog Output Card (Optional)

The analog output card (Plug-in card LON OUTA) is used for further processing of measured values as analog signals for an external device (e.g. analog display, digital display).

There are 4 analog outputs available from -10 V to $+10\text{ V}$.



The plug-in card LON OUTA is connected in the communication desk.

2.9 Measurement Programs

This dynamometer provides an exact simulation of defined road load conditions.

Fuel consumption measurement and exhaust analysis, as well as serial monitoring of vehicles can be carried out.

The following operation modes can be selected for conducting the various measurement tasks:

- **Load Simulation**

The user can pre-select from various load conditions which make possible the determination of e.g. a specific engine diagnosis or vehicle climbing power. Depending upon need, various load conditions can be simulated such as constant traction, a constant speed, a constant RPM or a driving simulation.

- **Measure Engine Power**

Use this menu item to determine the vehicle's engine power (continuous and discrete measurement).

- **Extrapolation of the Engine Power (Optional)**

Extrapolation of the engine power based on DIN 70020, EWG 80/1269, ISO 1585, JIS D 1001, SAE J 1349.

- **Flexibility Test**

The engine flexibility can be checked using this menu item. Once the flexibility test has been called up the vehicle weight and road load must be entered as in the road load simulation test.

- **Speedometer Test**

The vehicle's speedometer can be tested using this menu item. The speed can be tested as well.

- **Road Load Adaption (Optional)**

Various dyno coefficients can be determined using this menu item. The iterative coefficient adaption can be done based on ECE or SAE J2264 standard.

- **Lug-Down Test (Optional)**

Use this menu item to do a diesel exhaust measurement under full load.

2.10 Calculation Basis

2.10.1 Road Load

Equation

$$F_x = \frac{P_{\text{Air}} \cdot 3,6 \cdot v^2}{v_{\text{ref}}^3} + \frac{P_{\text{Flex}} \cdot 3,6 \cdot v}{v_{\text{ref}}^2} + \frac{P_{\text{Roll}} \cdot 3,6}{v_{\text{ref}}} + a \cdot m$$

with

- v_{ref} Reference speed for resistance performance values - normally 90 km/h.
- v Driving speed
- P_{air} Air resistance performance [kW]
- P_{flex} Flex performance [kW]
- P_{Roll} Roll resistance performance [kW]
- $a \cdot m$ Vehicle mass

Air resistance power P-Air [kW]

The air resistance power is proportional to the surface of the vehicle front and air resistance coefficient c_w .

$$P_{\text{Air}} = 0,5 \cdot \rho \cdot c_w \cdot A_{\text{Front}} \cdot (v + v_0)^2 \cdot v$$

with e.g.

- | | | | |
|--------------------------------------|--------------------|---|------------------------------------|
| • Air density | ρ (rho) | = | 1.1 kg/m ³ |
| • air resistance coefficient | c_w | = | 0.38 |
| • Front surface (VEH-width x Height) | A_{Front} | = | 1.7 m · 1.47m = 2.5 m ² |
| • Driving speed | v | = | 90 km/h = 25 m/s |
| • Head wind speed | v_0 | = | 0 m/s |

results:

- $P_{\text{air}} = 0,5 \cdot 1,1 \cdot 0,38 \cdot 2,5 \cdot 25^2 \cdot 25 = 8.164 \text{ kW at } 90 \text{ km/h}$

Flex power P-Flex [kW]

Flex power or resistance is defined as the power loss which occurs due to the flexing of the tire on the road surface and/or roller.

$$P_{\text{Flex}} = \mu_w \cdot m \cdot g \cdot v$$

Generally speaking the flex power does not have a relevant influence on the test results due to the minimal flex resistance coefficient.

Roller Resistance Power P-Roll [kW]

The rolling resistance power arises from tire and road surface deformation as a function of speed:

$$P_{\text{Roll}} = \mu_r \cdot m \cdot g \cdot v$$

with e.g.

- Roll resistance coefficient of the tires $\mu_r = 0.012$
- Vehicle mass $m = 950 \text{ kg}$
- Gravitation constant $g = 9.81 \text{ m/s}^2$
- Driving speed $v = 90 \text{ km/h} = 25 \text{ m/s}$

the result is:

- $P_{\text{Roll}} = 0.012 \cdot 950 \cdot 9.81 \cdot 25 = 2.79 \text{ kW}$

Since this value only represents a small fraction of the total Road Load it is entered as a fixed standard value on our dynamometers: for steel belted radial tires approx. 2.5 kW, for winter tires approx. 3.75 kW.

Setting of the vehicle mass, the aerodynamic drag power and the rolling resistance power is absolutely necessary for Road Load simulation and stop watch tests, in order to simulate the vehicle under the correct Road Loads.

Mass m = Vehicle mass [kg]

This value is needed in order to attain a proportional traction F via the eddy-current brake from the vehicle determined acceleration.

$$F = m \cdot a \text{ [N]}$$

2.10.2 Torque

Equation

$$M = \frac{P \text{ [kW]} \cdot 9549}{n \text{ [U/min]}}$$

2.10.3 Extrapolation of the Engine Power with Gasoline Engines

- DIN 70020 ⇒

$$K_a = \frac{1013}{p[\text{mbar}]} \cdot \left(\frac{T[\text{K}]}{293} \right)^{0.5}$$

- EEC 80/1269 ⇒

$$K_a = \left(\frac{990}{p[\text{mbar}]} \right)^{1.2} \cdot \left(\frac{T[\text{K}]}{298} \right)^{0.6}$$

- ISO 1585 ⇒

$$K_a = \left(\frac{990}{p[\text{mbar}]} \right)^{1.2} \cdot \left(\frac{T[\text{K}]}{298} \right)^{0.6}$$

- SAE J1349 ⇒

$$K_a = \left(\frac{990}{p[\text{mbar}]} \right)^{1.2} \cdot \left(\frac{T[\text{K}]}{298} \right)^{0.6}$$

- JIS D1001 ⇒

$$K_a = \left(\frac{990}{p[\text{mbar}]} \right)^{1.2} \cdot \left(\frac{T[\text{K}]}{298} \right)^{0.6}$$

with

- K_a correction factor
- p Atmospheric pressure at the dyno in mbar (1 mbar = 0.001 bar)
- T Air temperature at the dyno in Kelvin ($0^\circ\text{C} = 273\text{ K}$)

e.g.

- ambient air pressure $p = 936\text{ mbar}$
- ambient temperature $T = 17^\circ\text{C} = 290\text{ K}$
- based on DIN 70200 the result is: $K_a = 1.07671$

2.10.4 Extrapolation of the Engine Power with Diesel Engines (Naturally Aspirated or Supercharged)

- DIN 70020 \Rightarrow
$$K_a = \frac{1013}{p[\text{mbar}]} \cdot \left(\frac{T[\text{K}]}{293} \right)^{0.5}$$

- EEC 80/1269 \Rightarrow
$$K_a = \left(\frac{990}{p[\text{mbar}]} \cdot \left(\frac{T[\text{K}]}{298} \right)^{0.7} \right)^{f_m}$$

- ISO 1585 \Rightarrow
$$K_a = \left(\frac{990}{p[\text{mbar}]} \cdot \left(\frac{T[\text{K}]}{298} \right)^{0.7} \right)^{f_m}$$

- SAE J1349 \Rightarrow
$$K_a = \left(\frac{990}{p[\text{mbar}]} \cdot \left(\frac{T[\text{K}]}{298} \right)^{0.7} \right)^{f_m}$$

- JIS D1001 \Rightarrow
$$K_a = \left(\frac{990}{p[\text{mbar}]} \cdot \left(\frac{T[\text{K}]}{298} \right)^{0.7} \right)^{f_m}$$

with

- f_m Engine factor (Standard = 0.3)

2.10.5 Extrapolation of the Engine Power with Turbodiesel Engines

- DIN 70020 ⇒

$$K_a = \frac{1013}{p[\text{mbar}]} \cdot \left(\frac{T[\text{K}]}{293} \right)^{0.5}$$

- EEC 80/1269 ⇒

$$K_a = \left(\left(\frac{990}{p[\text{mbar}]} \right)^{0.7} \cdot \left(\frac{T[\text{K}]}{298} \right)^{1.5} \right)^{f_m}$$

- ISO 1585 ⇒

$$K_a = \left(\left(\frac{990}{p[\text{mbar}]} \right)^{0.7} \cdot \left(\frac{T[\text{K}]}{298} \right)^{1.2} \right)^{f_m}$$

- SAE J1349 ⇒

$$K_a = \left(\left(\frac{990}{p[\text{mbar}]} \right)^{0.7} \cdot \left(\frac{T[\text{K}]}{298} \right)^{1.5} \right)^{f_m}$$

- JIS D1001 ⇒

$$K_a = \left(\left(\frac{990}{p[\text{mbar}]} \right)^{0.7} \cdot \left(\frac{T[\text{K}]}{298} \right)^{1.5} \right)^{f_m}$$

with

f_m Engine factor (Standard = 0.3)

The extrapolation formula for Turbodiesel engines in the ISO 1585 only applies to air cooled charge-air coolers. The following equation applies to water cooled charge-air coolers:

- ISO 1585 ⇒
(water cooled)

$$K_a = \left(\left(\frac{990}{p[\text{mbar}]} \right)^{0.7} \cdot \left(\frac{T[\text{K}]}{298} \right)^{0.7} \right)^{f_m}$$

2.10.6 Calculate Engine Factor f_m

In most cases $f_m = 0.3$ applies but this value can be changed.
The following equations are used:

Engine factor f_m based on ISO 1585:

$37,2 \leq \frac{q}{r} \leq 65$	$f_m = 0,036 \cdot \frac{q}{r} - 1,14$
$\frac{q}{r} < 37,2$	$f_m = 0,2$
$\frac{q}{r} > 65$	$f_m = 1,2$

Engine factor f_m based on EWG 80/1269, SAE J1349 and JIS D1001:

$40 \leq \frac{q}{r} \leq 65$	$f_m = 0,036 \cdot \frac{q}{r} - 1,14$
$\frac{q}{r} < 40$	$f_m = 0,3$
$\frac{q}{r} > 65$	$f_m = 1,2$

Pressure behavior of the supercharging:

$r = \frac{P_L}{P_E}$

Specific fuel consumption based on SAE J1349:

4-Takt Motoren	$q = 120000 \cdot \frac{F}{D \cdot n}$
2-Takt Motoren	$q = 60000 \cdot \frac{F}{D \cdot n}$

with

- f_m Engine factor
- r Pressure behavior of the supercharging
- q Specific fuel consumption based on SAE J1349
- p_L Absolute boost pressure
- p_E Absolute pressure in front of the compressor
- F Fuel flow (mg/s)
- D Cubic capacity volume
- n Engine RPM

2.10.7 4 Wheel Drive Operation

Traction Regulation

The traction target value is divided in the front and rear as a function of the support roller RPM.

$$F_{X_v} = \frac{n_{St-v}}{n_{St-v} + n_{St-h}} \cdot F_x$$

$$F_{X_h} = \frac{n_{St-h}}{n_{St-v} + n_{St-h}} \cdot F_x$$

with

- F_{X_v} Traction front
- F_{X_h} Traction rear
- n_{St-v} Support roller RPM front
- n_{St-h} Support roller RPM rear
- F_x Traction total

RPM Regulation

The variable (control of the eddy current brake) is divided between the front and rear axle. This happens again as a function of the support roller RPM.

$$y_v = \frac{n_{St-v}}{n_{St-v} + n_{St-h}} \cdot y$$

$$y_h = \frac{n_{St-h}}{n_{St-v} + n_{St-h}} \cdot y$$

with

- y_v Variable front
- y_h Variable rear
- n_{St-v} Support roller RPM front
- n_{St-h} Support roller RPM rear
- y Variable total

Road Load Simulation

The traction target value which is calculated from the individual Road Loads, is divided between the front and rear axle as with the normal traction regulation.

3 Description of the SINAMICS Components

3.1 Special Safety Instructions for the SINAMICS Components

Commissioning shall not start until you have ensured that the machine in which the components described here are to be installed complies with Directive 2006/42/EC.

SINAMICS S equipment must only be commissioned by suitably qualified personnel.

The personnel must take into account the information provided in the technical customer documentation for the product, and be familiar with and observe the specified danger and warning notices.



When electrical equipment and motors are operated, the electrical circuits automatically conduct a dangerous voltage.

Dangerous mechanical movements may occur in the system during operation.

All work on the electrical system must be performed after the system has been switched off and disconnected from the power supply.

SINAMICS S equipment with three-phase motors may only be connected to the line system via residual current devices (RCDs) if compatibility of the SINAMICS equipment with the RCD has been ensured as specified in EN 50178, Subsection 5.2.11.2.

Correct and safe operation of SINAMICS S equipment assumes correct transportation, storage, setup, and installation, as well as careful operation and maintenance.



The details in the catalogs and proposals also apply to the design of special equipment versions.

In addition to the danger and warning information provided in the technical customer documentation, the applicable national, local, and system-specific regulations and requirements must be taken into account.

Only protective extra-low voltages (PELVs) that comply with EN 60204-1 must be connected to all connections and terminals between 0 and 48 V.

A hazardous voltage will be present in the component for a further 5 minutes after the system has been shutdown. Work cannot be carried out until this time has elapsed.

Before starting work, you should also measure the voltage after the 5 minutes have elapsed.

The voltage can be measured on DC link terminals DCP and DCN.



The clearances above, below, and in front of the component, which are specified in the dimension drawings, must be observed.

The DC link discharge time hazard warning must be affixed to the component, in the local language.

In a supply system without regenerative capability (e.g. diesel generator), the regenerative feedback capability of the Active Line Module must be deactivated via a parameter (see Description of Functions). The braking energy must then be dissipated via an additional Braking Module with a braking resistor in the drive line-up.



As part of routine tests, SINAMICS equipment with three-phase motors will undergo a voltage test in accordance with EN 50178. Before the voltage test is performed on the electrical equipment of industrial machines to EN 60204-1, Section 19.4, all connectors of SINAMICS equipment must be disconnected/unplugged to prevent the equipment from being damaged.

Motors must be connected in accordance with the circuit diagram provided. They must not be connected directly to the three-phase supply because this will damage them.



Operating the equipment in the immediate vicinity (< 1.5 m) of mobile telephones with a transmitter power of > 1 W may lead to incorrect operation.



When operated in dry operating areas, SINAMICS equipment with three-phase motors conforms to low-voltage Directive 73/23/EEC.

SINAMICS equipment with three-phase motors conforms to EMC Directive 89/336/EEC in the configurations specified in the associated EC Certificate of Conformity.

3.2 Mains Connection for Booksize Drive Assembly

The mains connection for the SINAMICS Booksize drive assembly consists of a mains line filter and a mains line choke:

- | | | |
|-----------------------------|---------------------|---------|
| A Supply Line from MSR Desk | D Mains Line Filter | G Motor |
| B Fuse | E Mains Line Choke | |
| C Contactor | F SINAMICS S120 | |

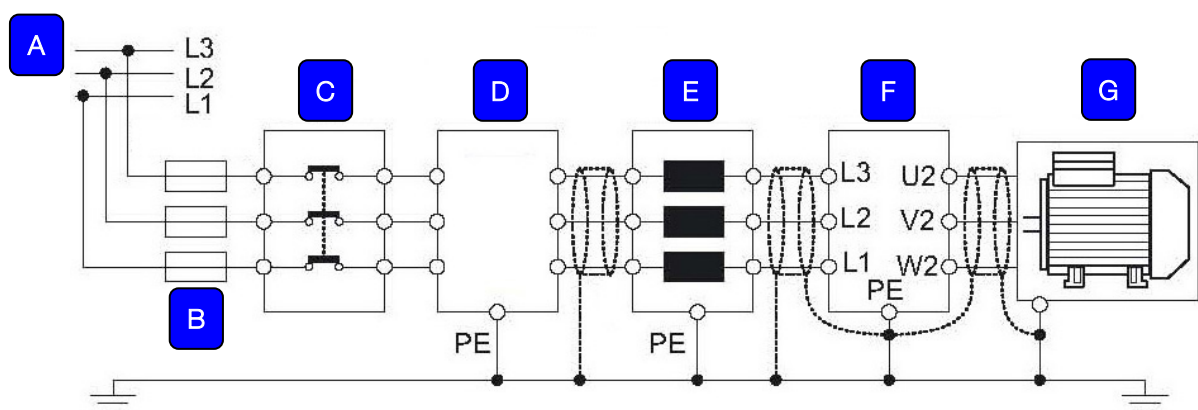

3.3 Basic Setup

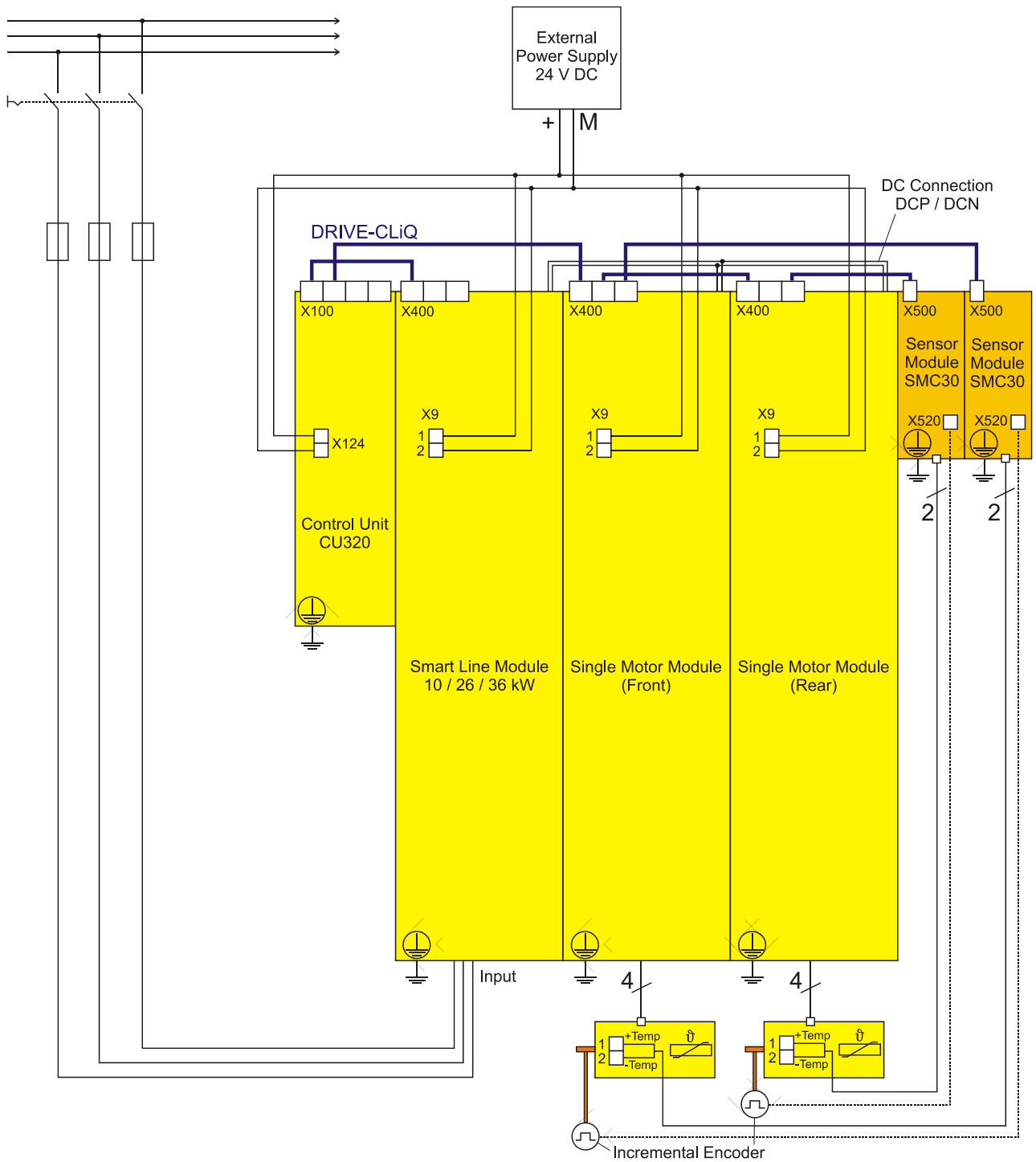

 See the enclosed circuit diagram for details.

4 Transport and Storage

Check package to ensure it is complete, in accordance with the order confirmation. Report any transport damage to the carrier immediately.

During loading, unloading and transport always use suitable lifting equipment, material handling equipment (e.g. cranes, forklifts, etc.) and the right load handling attachments and slings. Always ensure that the parts to be transported are suspended or loaded properly so that they cannot fall, taking into account size, weight and the centre of gravity.

Store the packages in a covered area, protected from direct sunlight, at a low humidity and with temperatures between 0...40 °C (32...104 °F). Do not stack packages.

When unpacking, take care to avoid any possibility of injury or damage. Keep at a safe distance when opening the package strapping, do not allow any parts to fall out.

5 Installation and Initial Operation

Installation and initial operation of the equipment may be done only by authorized and trained service technicians provided by the manufacturer, licensed dealers or service partners.

6 Installation

6.1 Requirements for the Place of Installation

The room in which the dyno is to be operated must satisfy all official regulations for the operation of equipment in the workplace.

An adequate fresh-air supply and an exhaust shaft should also be available.

6.2 Safety Measures



The following technical safety precautions must be observed by the customer at all times.

Disregarding these precautions can be life-threatening even for those who enter the room for only a very short period.

6.2.1 Heat Balance

Rough calculation for diesel and Otto engines

The available energy in fuel is taken as standard. This is specified as fuel power with 100 % and is divided as follows:

P_1	29 %	= Engine power (mechanical) Degree of effectiveness over the entire RPM range
P_2	23 %	= Heat flow over the engine block surface and engine components.
P_3	20 %	= Coolant heat flow (is transmitted via the vehicle cooler)
P_4	14 %	= Heat flow via the surface of the vehicle exhaust system
P_5	14 %	= Heat flow of the exhaust

Heat volume in the test room

$$P_1 + P_2 + P_3 + P_4$$

P_1 : Is converted to heat by the air cooled eddy current brake and normally emitted into the test room.

P_5 : This energy is suctioned out with the exhaust suction system and does not contribute to heat volume in the test room.

Generally speaking the engine power to be measured is known. If this is specified with 1, the following factors are given:

P_1	Engine power	1
P_2	Heat flow surface engine block	0.8
P_3	Coolant heat flow	0.7
P_4	Heat flow vehicle exhaust system	0.5

The heat volume in test room is then: $1 + 0.8 + 0.7 + 0.5 = 3$

This means that the energy quantity of the engine power multiplied by 3 is the volume of heat energy in the test room.

Example 1	P_1 Engine power		= 100 kW
	P_2 Heat flow surface engine block	0.8×100	= 80 kW
	P_3 Coolant heat flow	0.7×100	= 70 kW
	P_4 Heat flow vehicle exhaust system	0.5×100	= 50 kW
			<u>Heat burden on the room = 300 kW</u>

Separate suction of the heat energy P_1 converted by the eddy current brake can considerably lower the burden on the room.

The heat volume in the test room would then be: $+ 0.8 + 0.7 + 0.5 = 2$

This means that the energy quantity of the engine power multiplied by 2 is the volume of heat energy in the test room.

Example 2	P_2 Heat flow surface engine block	$0,8 \times 100$	= 80 kW
	P_3 Coolant heat flow	$0,7 \times 100$	= 70 kW
	P_4 Heat flow vehicle exhaust system	$0,5 \times 100$	= 50 kW
			<u>Heat burden on the room = 200 kW</u>

- Time period

An LPS 3000 performance test takes, on the average:

CAR	1.5 minutes
TRUCK	3 – 4 minutes

A short working break follows (vehicle change, set up work, etc.)

- Ventilation concept criteria

The following points must be considered for the ventilation concept:

- Engine power
- Frequency of measurements
- Room temperature increase allowed by operator
- Room size
- Energy storage volume of the walls

MAHA Experiences

Cooling air is of special importance as modern engine management systems are equipped with control systems which reduce the engine power when intake temperatures are too high. The full engine power is however to be measured on the dyno.

Do not fall below the following values when testing vehicles under full load:

- Air power > 25 000m³/h
- Flow speed > 90 km/h
- Securing of under body flow (catalytic converter)

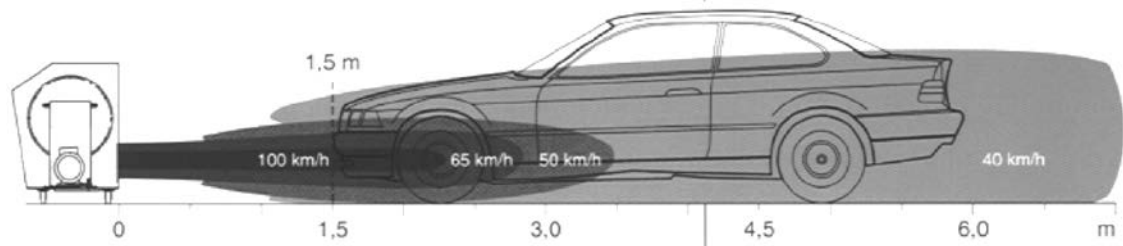

6.2.2 Exhaust Suction System

The exhaust quantity depends upon the test vehicle. The factors which are most influential are the engine cubic capacity and RPM as well as the combustion process (spark or compression ignition).



As a safety precaution it is recommended that a CO warning device be installed in the test room.

Equation for dimensioning of exhaust suction systems (see also TRGS 554, section 4.7.4.3, paragraph 2).

$$V = V_h \times n \times 0.0363 \times 1.2$$

V = necessary suction volume flow (m³/h)

V_h = cubic capacity of the test vehicle (l)

n = engine speed of the test vehicle (rpm)

0.0363 = approximate value

1.2 = fresh air share of 20 %

Experimental values based on BG-BIA / ASA-recommendations *:

Car workshop Service/Repair	Car workshop Test room + AU	Truck workshop Service/Repair	Truck workshop Test room + Emission test
350...450 m ³ /h	700...1200 m ³ /h	700...1200 m ³ /h	1700...2800 m ³ /h
Hose Ø	Hose Ø	Hose Ø	Hose Ø
100 mm	150 mm	125 – 150 mm	200 mm

* Measurement point: Interface recording element-exhaust hose

Pay attention to temperature consistency. The respective exhaust suction system must be adapted to the needs of the operator.

It is recommended that the exhaust suction system not be combined with a welding smoke suction system and then connected to a ventilator. It is possible that a combustible or explosive mixture may be created based (see ZH 1/454 vehicle maintenance guideline).

Example for calculation based on the equation $V = V_h \times n \times 0.0363 \times 1.2$

Example 1	Example 2
Car with 3.0 liter cubic capacity, service work with average speed of 3000 rpm	TRUCK 12.0 Liter cubic capacity, service work with average speed of 1500 rpm
$V = 3.0 \times 3000 \times 0.0363 \times 1.2$	$V = 12.0 \times 1500 \times 0.0363 \times 1.2$
$V = 392.04 \text{ m}^3/\text{h}$	$V = 784.08 \text{ m}^3/\text{h}$

The exhaust discharge for the auto exhaust can be done with suction hoses (air flow rate > 3000 m³/h) or with suction flaps (air flow rate approx. 10000 m³/h) .

Example for calculation at dynamometers $V_t = V_h \times (t \text{ in } ^\circ\text{C}:273 \text{ Kelvin}) \times \lambda$

λ = Supply degree of 0.85 (without Turbocharger)...approx. 1.9 (depending on engine and manufacturer)

Example 1	Example 2
Car dyno, Engine 5.547 liter, Engine speed 5000 rpm, Temperature 500°C, $\lambda = 1.0$	Truck dyno, Engine 18.273 liter, Engine speed 2300 rpm, Temperature 500 °C, $\lambda = 1.5$
$V_t = 5.547 \times 5000 \times 0.0363 \times 1.2 \times 500/273 \times 1.0$	$V_t = 18.273 \times 2300 \times 0.0363 \times 1.2 \times 500/273 \times 1.5$
$V_t = 2212.71 \text{ m}^3/\text{h}$	$V_t = 5029.49 \text{ m}^3/\text{h}$

6.2.3 Fresh Air Supply for the Test Room

According to currently effective regulations in the Federal Republic of Germany, the air must be renewed 10 to 15 times per hour in closed testing rooms with a surface area up to 100 m².

The air must be renewed 5 to 8 times per hour in rooms over 100 m².

An air throughput of approx. 5000 m³/h is required for a surface area of 100 m².



An inadequate fresh-air supply increases the burden on the test personnel and distorts the test results.

7 Software

7.1 System Requirements

OSWin XP with SP 2; Win Vista (32 Bit) for ES v7.00.015 or later; Win 7 for ES v7.10.001 or later
 CPU> 1.6 GHz; recommended: Intel or similar AMD products
 HDD 1 GB free memory space
 Graphics card Resolution 1024 x 768 with 24 bit color depth (True Color)
 RAM..... Win XP: 512 MB; Win Vista or Win 7: 1 GB
 Drives..... DVD-ROM
 Interfaces2 free USB interfaces

- If using Win 7, please read section *Additional Settings under Windows 7* before installing the application software!
- All passwords and administrator rights must be available at the time of the installation.
- If the tester is used with multiple work stations, a TCP/IP network must be available.
- For external devices with RS232 connectors an RS 232 interface must be available.
- PC speciality stores offer a wide range of USB-to-RS232 adapters. There is, however, no standard guarantee that every adapter will function on the RS232 interfaces. For this reason, MAHA offers adapters with the order number (VZ 910140) which have been tested on MAHA products.
- When replacing old computers with PC-LON cards (ISA slot), be aware that new computers no longer have ISA slots. For new computers that means that a LON-USB card (VZ 912033) is needed for the connection to the test lane.



7.2 Starting the Setup

- 1 Insert the CD in the disk drive.
 => Installation starts automatically.
 If not, start **Auto-run.exe** or **EU-ROSYSTEM\Setup.exe** from the CD.
- 2 To start the setup click the equipment type being used.

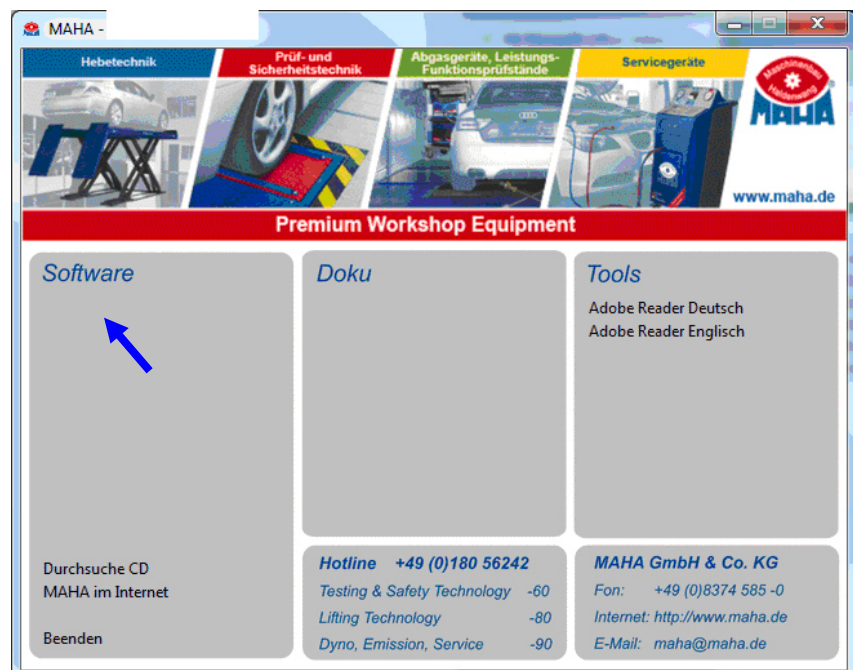

7.3 Selecting the Setup Language

- 1 Choose a setup language. German and English are available.
- 2 Confirm with <Next>.

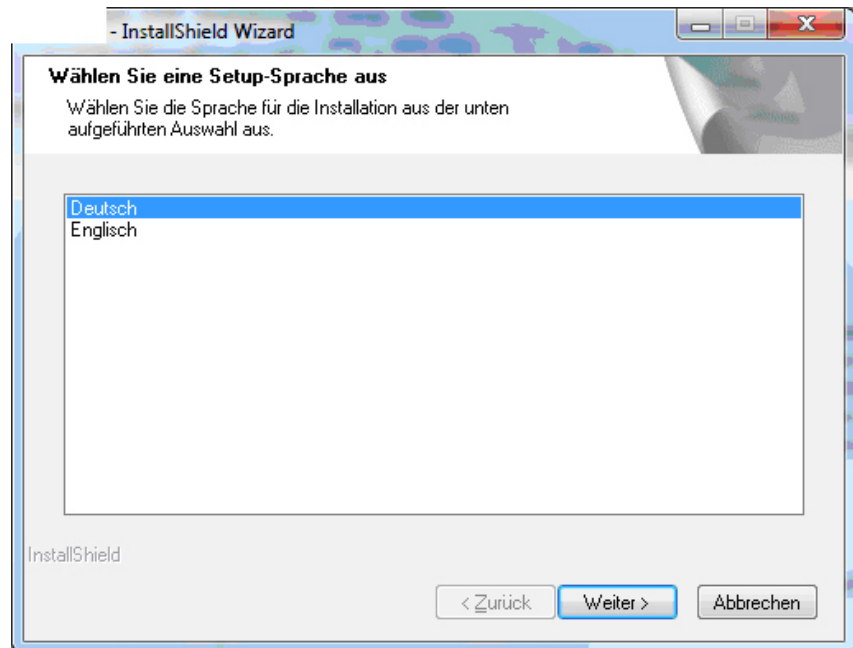

- ⇒ The InstallShield Wizard appears.
- 3 Confirm with <Next>.

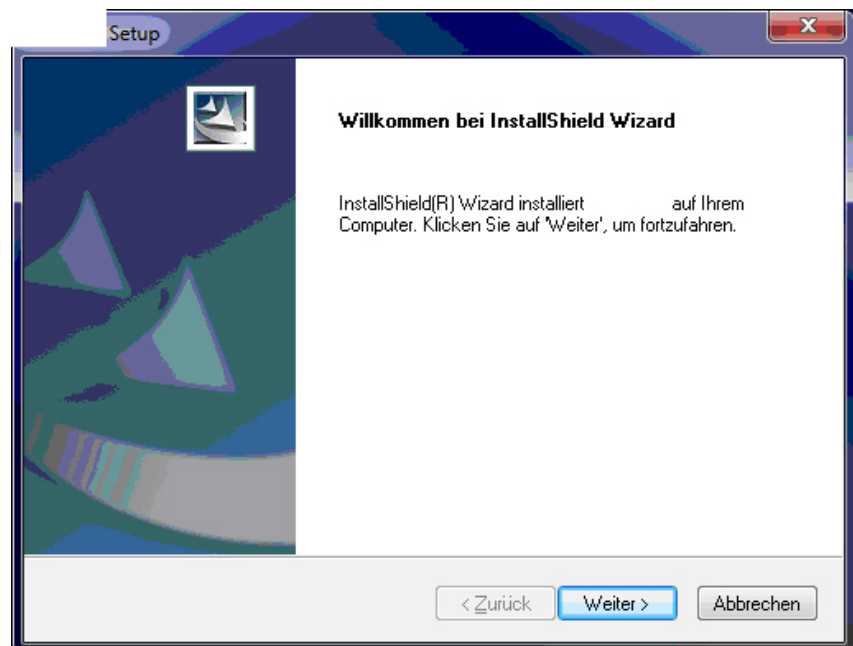

7.4 Selecting the Destination Folder

- 1 Choose the default destination folder or click <Browse> to select a different folder.
- 2 Confirm with <Next>.

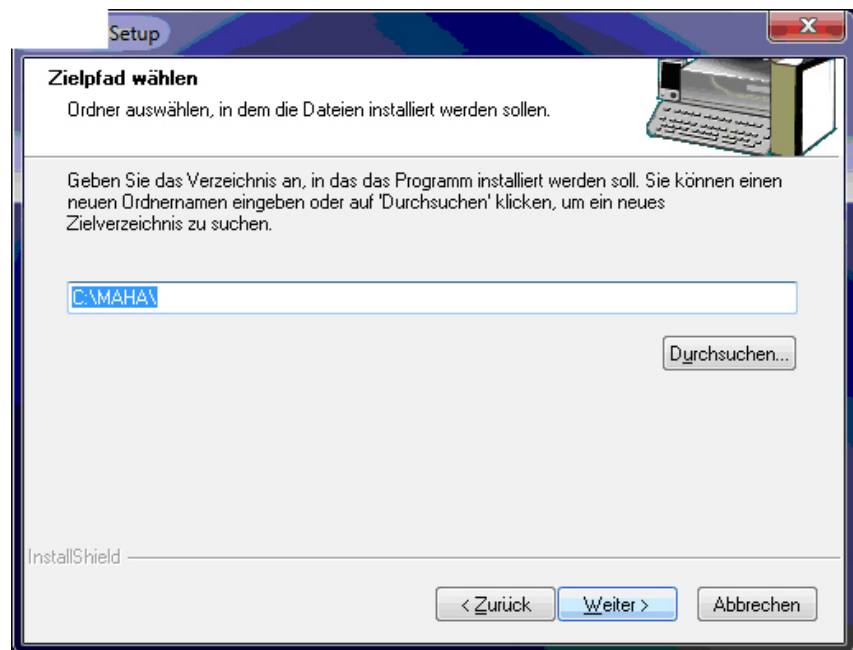

7.5 Selecting the SQL Server

- 1 Select the SQL server.
- 2 Confirm with <Next>.

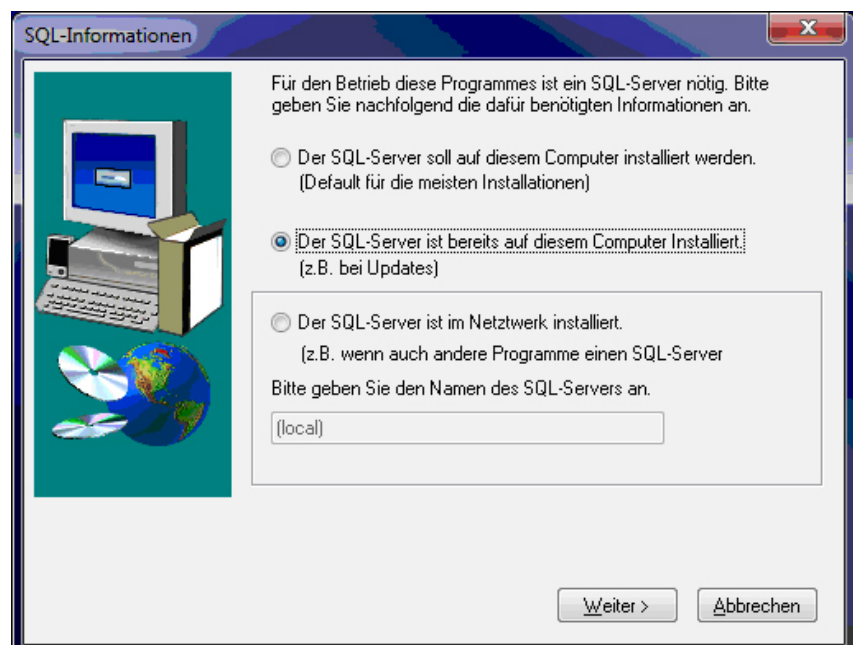

7.6 Selecting the Dyno Type

- 1 Choose the dyno type.
- 2 Confirm with <Next>.

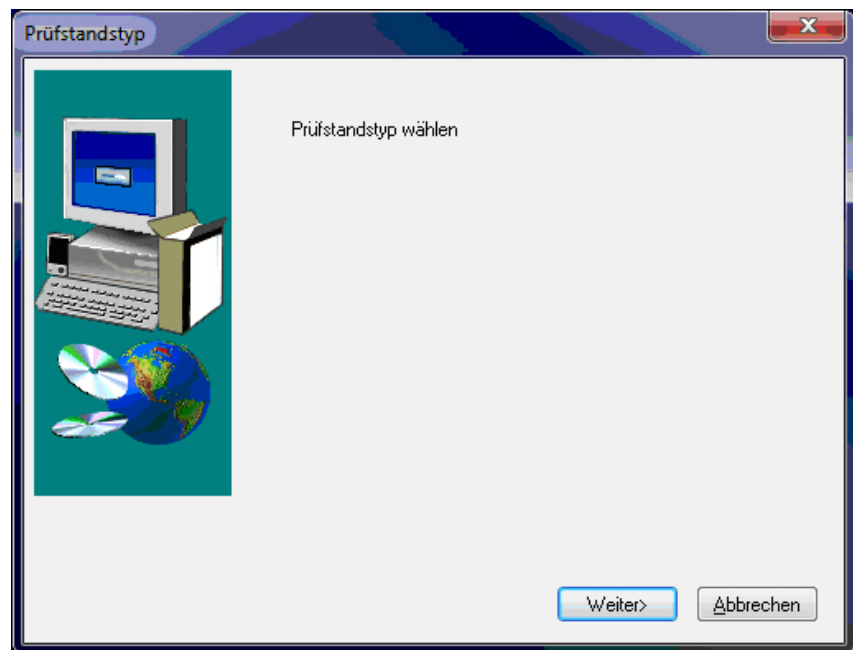

7.7 Selecting Features

- 1 Mark the checkboxes of the features you want to install.
- 2 Confirm with <Next>.

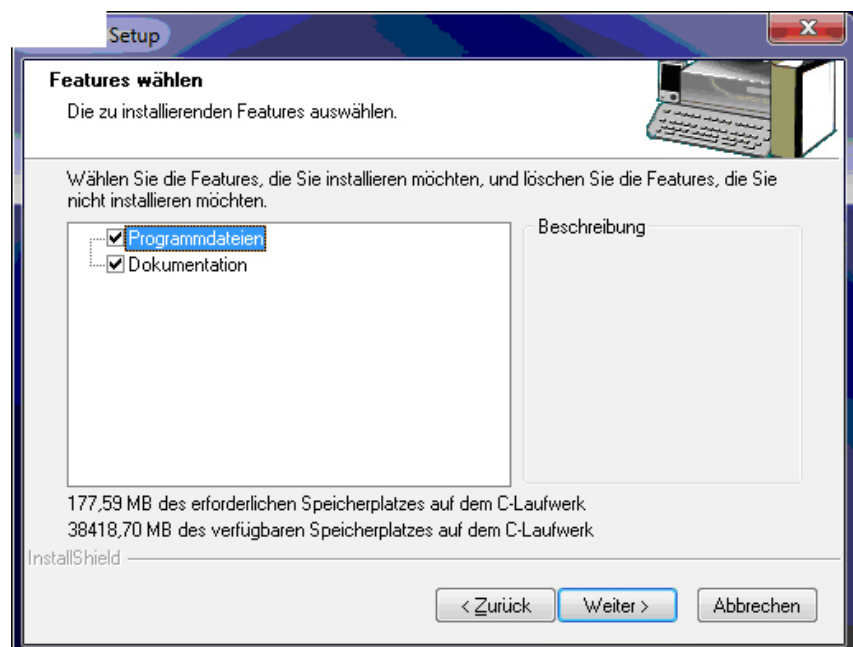

7.8 Installing Drivers

- 1 Install the required drivers.

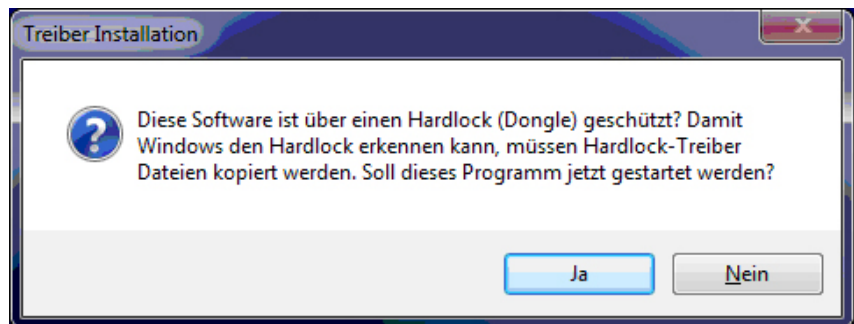

7.9 Finishing the Setup

- When this window appears, the installation has been successfully completed.
- 1 Click <Finish> to exit the InstallShield Wizard.

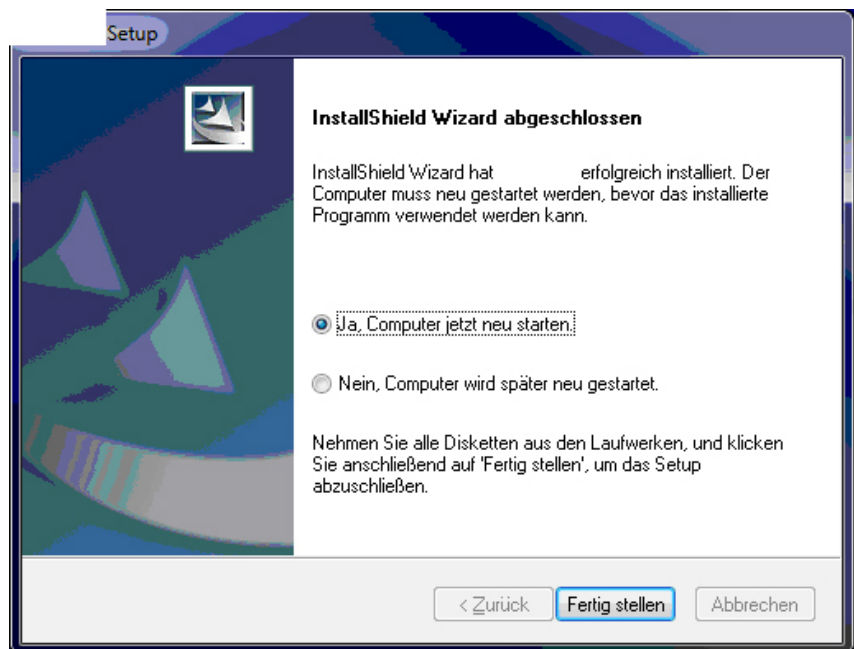

7.10 Additional Settings under Windows 7 or higher

Prior to installation disable the Windows Update function:

- Control Panel
- System
- Advanced system settings
- Hardware
- Device Installation Settings ▶

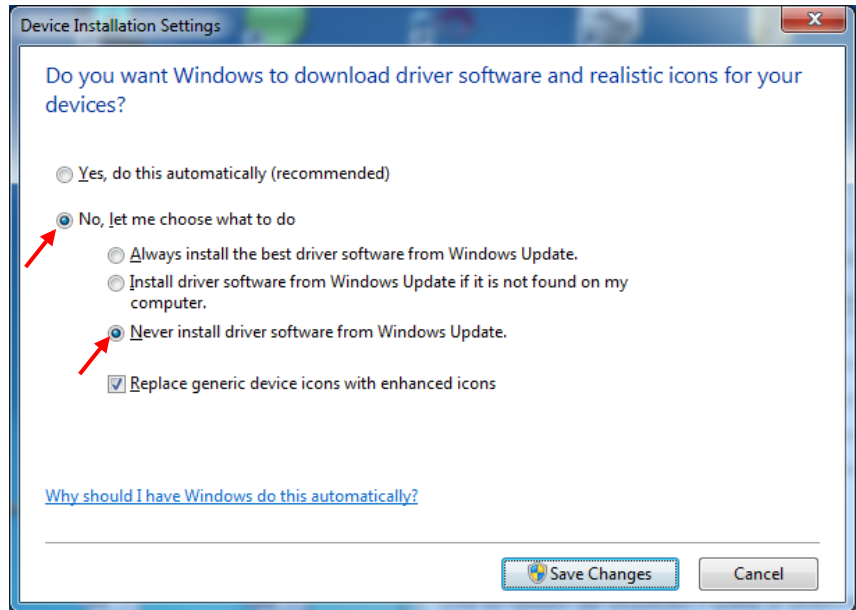

After inserting the EUROSYSTEM CD "AutoRun" is started. Use this program to install your version of EUROSYSTEM. Click the equipment being used (1).



Provided the User Account Control is enabled, this Windows confirmation prompt appears.

Confirm with "Yes".

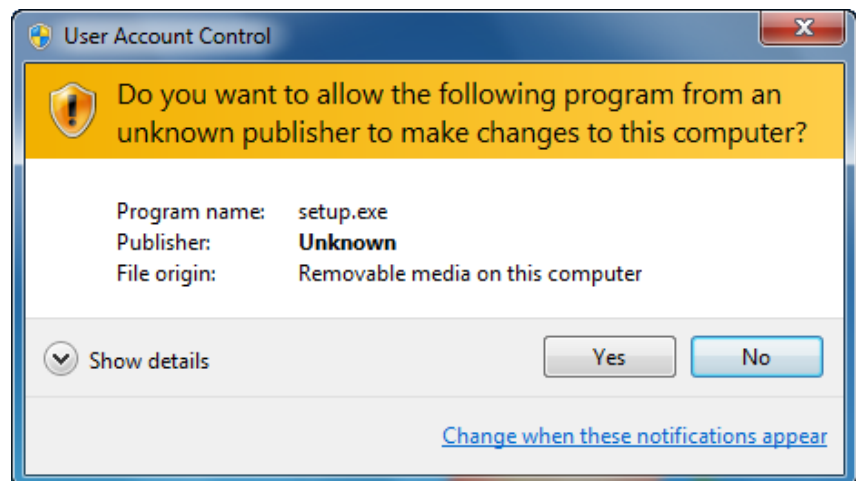

Do the software installation as described above, starting with step "Selecting the Setup Language".

After the installation process has been successfully completed, assign the user rights for the directory. To do this, open the installation directory, usually located at: C:\Programs\MAHA\ [Equipment type], then right-click the folder. In the object menu, select "Properties" (2).

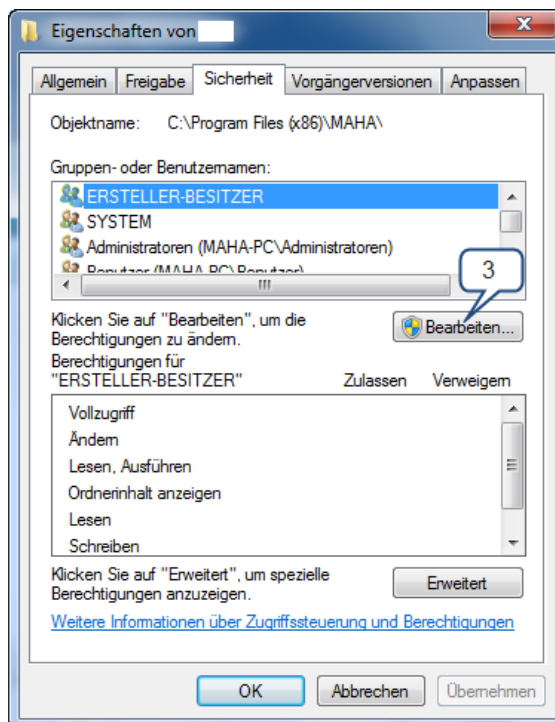
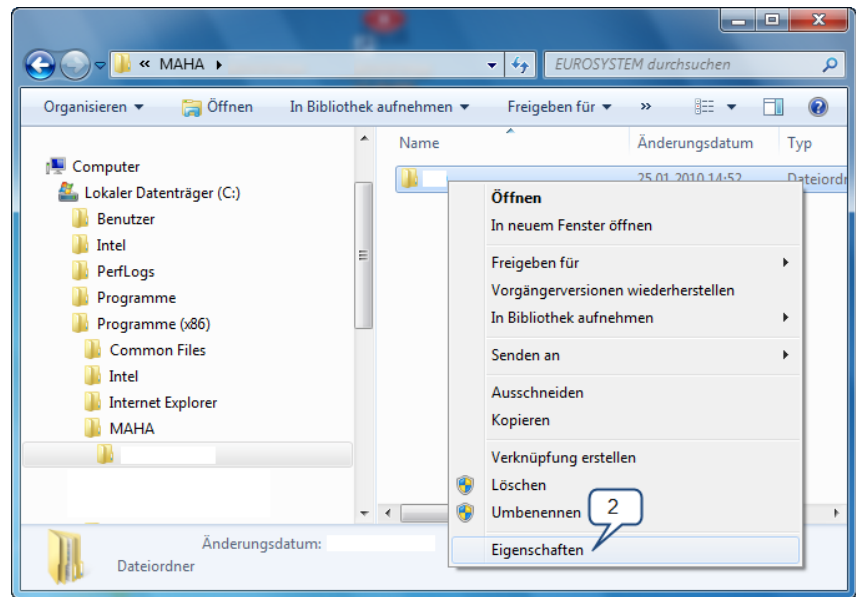

In this dialog window, click tab "Security" and then button "Edit" (3).

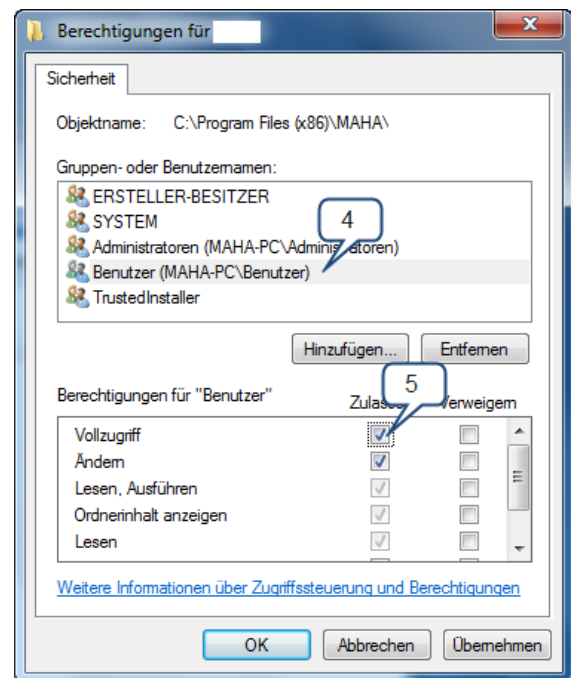

Now the user rights can be assigned. Mark entry "Benutzer" (German for "User") (4) and tick the "Allow" checkbox next to the "Full control" permission. (5).

Confirm the assignment with "OK". The new permissions will now be applied.

8 Preparations for Testing

8.1 Switch on the Dyno

- 1 Switch on the main switch at the communication desk.
- 2 Turn the Operating mode switch to position 2 "Setup".
- 3 Push the Control ON button.



See also section "Description / Controls and Indicators".

8.2 Drive onto Dyno and Secure Vehicle



Risk of injury by flying particles!

- Before driving onto the rollers, remove all particles such as gravel etc. from the tires.
- Check the balancing weights on the rims for tight fit.
- Wear protective glasses.



- 1 Block the rollers.
- 2 Position the front axle in the center on top of the front roller set.
- 3 Put on the parking brake.
- 4 Fix the vehicle at the front with tightening straps, and with chains at the rear. The anchoring should be tight, but not pull down the vehicle.
- 5 Release the parking brake and shift to idle position.
- 6 Move the rear roller set until the rear axle also sits centered on the top.
- 7 Retighten the vehicle fixing again.
- 8 Release the roller blocking.

Life-threatening injuries possible if vehicle breaks loose from fixing!

- No persons shall be in the test room during vehicle testing! Danger!
- Fix the test vehicle before each test at the rear and front onto the dyno with the proper (MAHA-) vehicle fixing. Usage of a different fixing attachment can affect safety and cause personal injury. MAHA accepts no liability for the resulting damage.
- The vehicle must be fixed in such a way that the vehicle cannot laterally break away and that no swinging movements are created!
- Safeguard that the vehicle mass cannot be moved on the rollers!
- Make sure that the vehicle fixing is suitable for the vehicle being tested.
- Only skilled, trained personnel shall install the vehicle fixing.
- Always install the vehicle fixing completely and properly and check its proper functioning before test start.
- Check the orderly condition and suitable rigidity of the vehicle's attachment unit before every vehicle fixing procedure (e.g. towing hooks, trailer coupling, towing attachment)!
- Fasten the chains and straps to suitable points at the vehicle chassis or suspension.
- If using tightening straps for anchoring pay close attention that the loose ends do not get close to the tires or rollers. This is especially important when the fan is switched on!
- Check the tightening straps for damage before each measurement.
- **Never** start the test operation without suitable and complete vehicle fixing!
- Visually check the vehicle for leakage: Fuel system, drive train, engine, water, exhaust.



8.3 Connect the RPM Sensor

- 1 Connect the RPM sensor in the engine compartment. The procedure depends upon the type of sensor. Please pay attention to the detailed description of the various RPM sensors in section "*Description / Interface Box*".
Set the RPM sensor using the selection list in window "RPM Sensor" in the menu "RPM Settings".
- 2 Connect the RPM sensor to the interface box.
Other data sensors which may be needed during the test should be connected according to the interface assignment plan for the interface box. Connect all needed sensors to the vehicle. Use the menu "RPM Settings" to check whether all connected measurement sensors are functioning correctly.



Automatic transmission vehicles without converter lockup cannot use the driving trial method, because the engine RPM deviates due to converter slip.

8.4 Connect Oil Temperature Probe

- 1 Remove the oil dipstick from the engine.
- 2 Adjust the length of the oil temperature probe to the length of the original dipstick by using the cone plug.



Risk of damage!

Incorrect length adjustment of the oil temperature probe can lead to engine damage!

-
- 3 Replace the oil dipstick with the oil temperature probe. Close the opening with the cone plug.

8.5 Attach Exhaust Suction System



Danger of poisoning by exhaust gases in the test room!



- Use an exhaust suction system.

-
- 1 Place the exhaust suction system close to the exhaust pipe and switch it on.



Risk of damage!

A certain distance should be maintained from the vehicle because of possible heat accumulation in the exhaust suction unit which may cause damage to vehicle or paint.

8.6 Position Cooling Air Fan

- 1 Position the cooling air fan in front of the vehicle's radiator.
- 2 To make sure that the fan remains in place during operation, use the fixing levers on the casters of the fan.
- 3 Switch on the air cooling fan.



Risk of damage!

Cables and tightening straps can get between tires and rollers due to the air flow.

8.7 Bring the Vehicle up to Operating Temperature

This can be done using the load simulation, e.g. with a constant traction (see section "*Load Simulation*").

8.8 Vehicle Ready for Testing

The vehicle is ready for testing when all the preparation steps for testing have been completed.

Life-threatening injuries possible by rotating dyno rollers!



- **Always** keep body parts and clothing far away from rotating rollers, as there is danger of these being pulled into the rotating rollers!
 - Safeguard that the operating personnel is informed when someone is underneath the dyno. Danger for those who are under the dyno without the knowledge of the operating personnel!
 - If this safety system has been bypassed, the service personnel is responsible for establishing necessary and suitable safety measures (e.g. signs which indicate that service work is being done).
 - Make sure that all keys for bypassing safety systems are only available to specially trained service personnel.
 - **Do not** leave the keys in the key switch during normal test operation.
-



Risk of hearing damage due to high noise level!

- Use ear protection which is approved for up to 120 dB(A). Noise levels of over 100 dB(A) are possible during vehicle testing.
-

8.9 Exit the Dynamometer

- 1 Block the rollers.
- 2 Remove the roller adjustment device from the rear axle in a backward direction.
- 3 Shift into 1st gear and put on the parking brake.
- 4 Loosen the tightening straps at the front axle.
- 5 Then loosen the tightening straps at the rear axle.
- 6 Remove all tightening straps.
- 7 Release parking brake and shift into idle.
- 8 Drive vehicle off dyno.

9 Program Structure

9.1 General Information

The program is menu-oriented. Data or instructions can be entered via the PC keyboard. The remote control is used for the setup operation, for e.g. wheelbase setting, starting and stopping of the pre-selected driving cycle.

The main menu is divided into several sub-menus which can be selected as follows:

- Wheel mouse: with mouse click
- Keyboard: Select with the Cursor keys and open with the <ENTER> key.



During the program procedure follow the instructions in the status line.

The following is described in the instructions:

- Program structure
- Starting the program
- Operation and explanation of the main screen and button strip
- End program / Switch off dyno

9.2 Tree Model

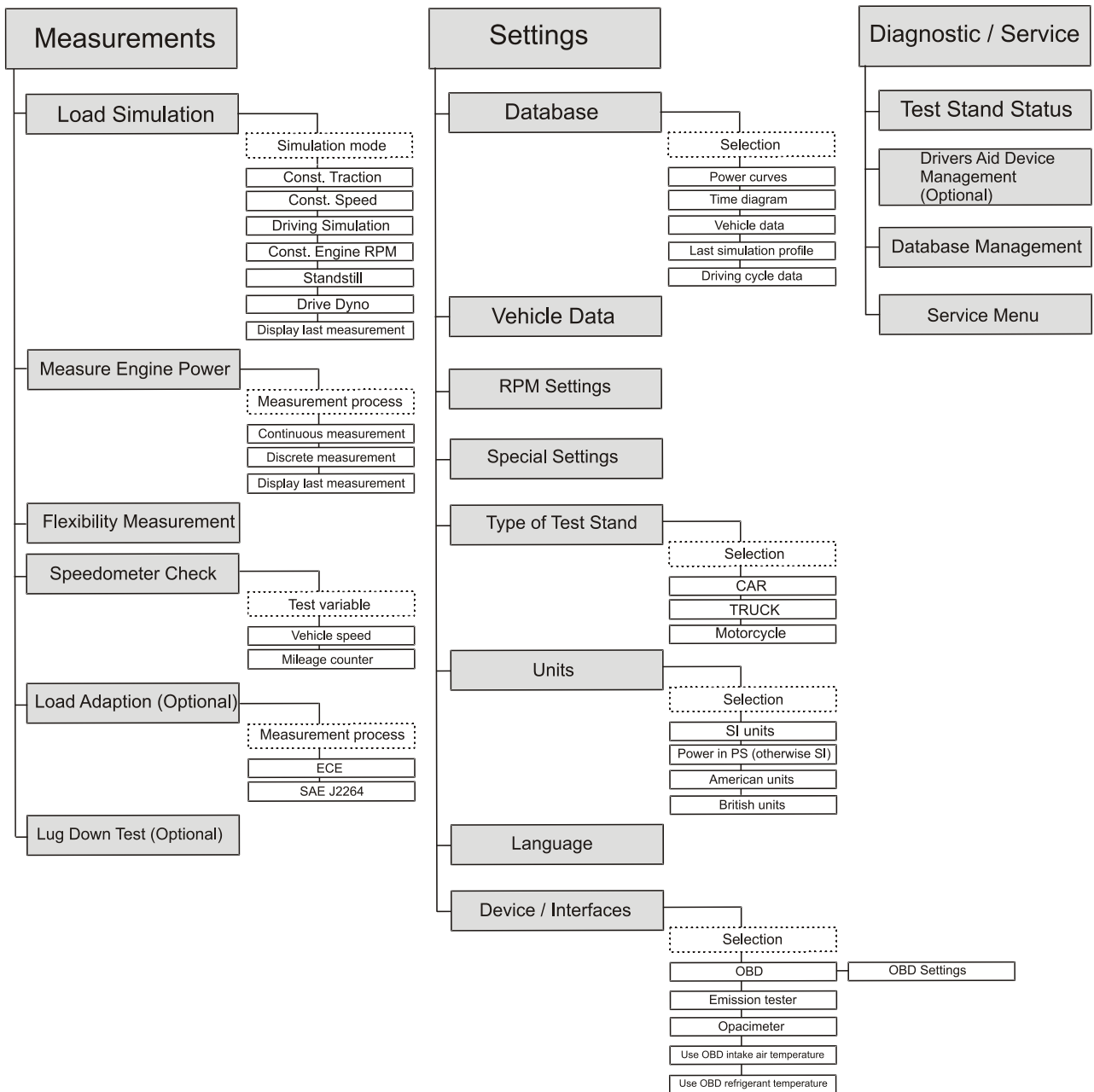

9.3 Screen Design

Generally the screen is divided up into the following areas:

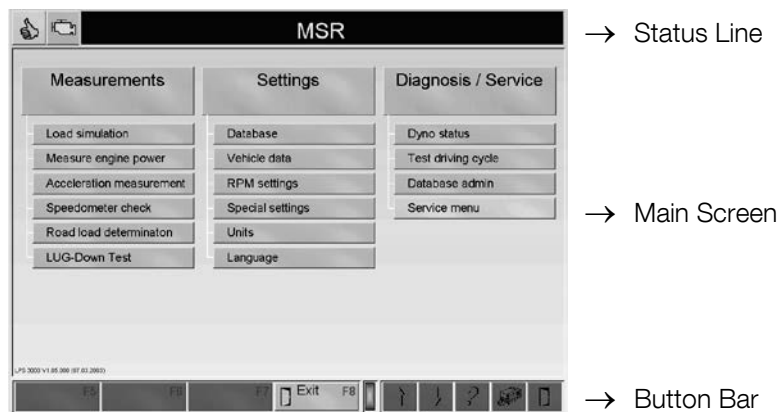

9.3.1 Status Line





The status line on each screen continuously informs the operator about the current status of the program, guides through the program with short information and provides information about the keys to be used. Further, malfunction and error messages are displayed.







The dyno model, the operating and functional conditions of the various devices are displayed in the status line.

The various symbols are described in the following section.



Always pay close attention to the messages and instructions in the status line!

Symbol	Description
	Dyno OK (green) The connection to the various dyno components (e.g. eddy current brake, interface box, etc.) are working trouble-free.
	An error has occurred, but it is possible to continue (yellow).
	An error has occurred, it is not possible to continue (red).
	Communication status to OBD (red: communication error green: communication OK) See section "OBD Settings" in chapter "Settings".

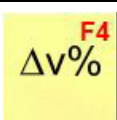
Symbol	Description
	Dyno is set for CAR (green).
	Fan (red: switched off green: switched on)
	Pneumatic holding brake of dyno rollers. Green: Brake of drive axle(s) selected is open – rollers can rotate freely. Red: All brakes are closed – rollers are blocked. Yellow: Position of brakes is not compatible with vehicle. Click on the symbol to close the brakes: "red". Click again to open the brakes: "green".
	Front Wheel Drive mode
	Rear Wheel Drive mode
	4 Wheel Drive mode
	For setting a speed difference (3 % max.) between HA (rear wheel drive) and FA (front wheel drive)

9.3.2 Main Screen

Here menu items can be selected or measurement variables displayed.



Grey shaded boxes are not available for selection.

To select a menu item from the main screen, either

- mark it using the cursor keys / the tab key and confirm with <ENTER>, or
- open it using a left mouse click.

9.3.3 Button Bar

Here are additional important functions. The assignment of buttons <F5> to <F8> in the button bar can vary. The individual buttons are labelled with the respective function and function key. The button assignments are explained later in the respective menu items as they appear.



The button bar assignments depend upon the screen currently active. Grey shaded buttons are not available for selection.

Example

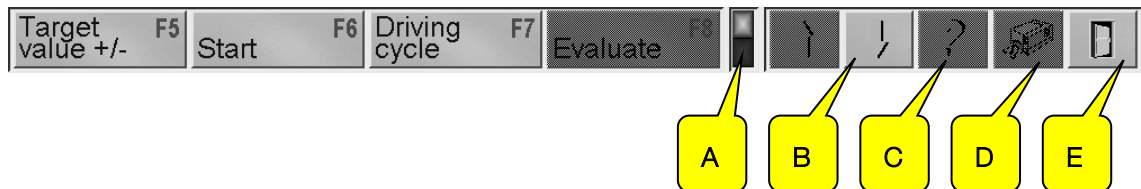

A+B SWITCH OVER Button

If the highlighted LED (A) appears in front of the arrow keys, this means the button bar has additional functions and can be "switched over" with the arrow keys (B) or with the <Pg ↓> or <Pg ↑> button or with the scrolling wheel of the mouse.

C INFO Button

Use this button to display various dyno information.

D PRINT Button

Use this key or the <F12> key to start a printout.

E ESCAPE Button

Use this button or the <Esc> key to exit the active screen.

9.4 Starting the Program

- 1 Switch on the dyno via the main switch on the communication desk.
 - 2 Windows is started after the PC is booted. Depending on the setting, the program is started either automatically, or by calling up the Start group or by double clicking the icon.
- The start screen appears with the MAHA logo and version number.
- The following screen appears which shows the connected PCBs.
-



The number of modules (PCBs) depends upon the options that have been ordered.

- 3 Confirm the enabling of the individual dyno components with the button

F8 CONTINUE

- 4 If desired, start a software update of the individual dyno components using

F7 UPDATE

→ After a few seconds the main menu appears.

9.5 End Program / Switch off Dyno



First quit the program and then shut down the computer properly. Improper termination can cause a system crash and data loss!

- 1 Quit all menu items with <ESC>.
- 2 As soon as you are in the main menu, quit the program with <F8 EXIT>.
- 3 Quit Windows and shut down the computer properly.
- 4 Turn off the main switch at the communication desk.

10 Measurements

10.1 Load Simulation

The Load simulation menu enables the user to preselect various load conditions which, for example, make possible targeted engine diagnosis or determination of the climbing performance of a vehicle. After selecting the menu item, the following screen appears:

- Const. traction
- Const. speed
- Road load simulation
- Const. Engine RPM
- Standstill
- Drive dyno
- Show last measurement

10.1.1 Identical Functions

Button Description

LEVEL 1

Target value +/-	F5	• The target value can be changed and confirmed during the measurement.
Target value OK	F5	• Change the value with the +/- keys or with the remote control scroll key. If the desired value is set, it is confirmed with the <F5> key.
Start	F6	• The graphic recording of the measurement is started or stopped.
Stop	F6	
Driving cycle	F7	• A driving cycle from the database can be selected.
Evaluate	F8	• The measurement evaluation is displayed.

LEVEL 2

Store	F5	• The measurement is stored.
Reset	F6	• The graphic recording of the measurement is reset to zero.
Profile	F7	• A display profile can be selected from the database.
Reset travel distance	F8	• The travel distance measurement is reset to zero.

LEVEL 3

Enter target value		• Use this button to change the current target value (e.g. Speed 50 km/h) without having to quit the program.
--------------------	--	---

Driving Cycle (Optional)

A speed profile with fixed time and speed run can be driven on the dyno using the button *Driving cycle*. The required curve plot is displayed on the screen for the test driver.

The various standard cycles are found in the directory *Cycles*. Load the cycles from here using the button <F8 LOAD>.

- 1 Use the button <F7 DRIVING CYCLE>
→ The following screen appears:
- 2 Use the button <F8 LOAD>

Driving cycle F7

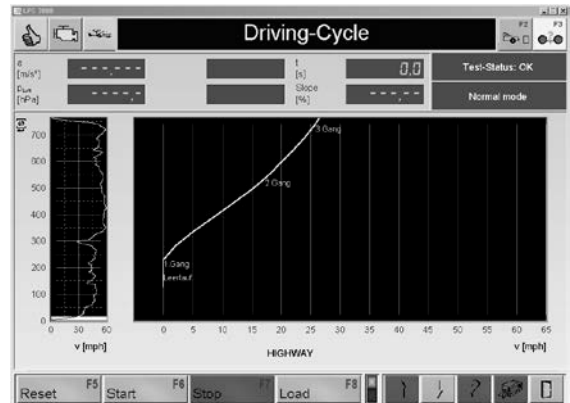

→ The selection screen appears.

- 3 Select the desired driving cycle with the cursor key or the mouse and load this with <OPEN>.

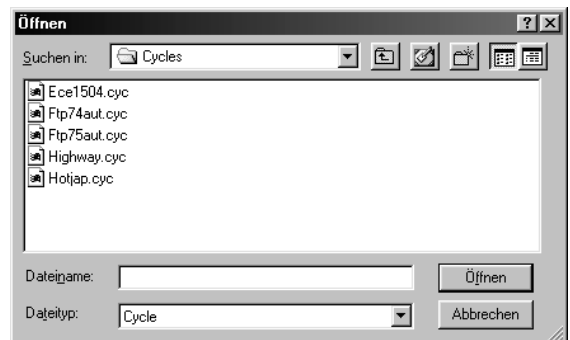

- 4 Start the driving cycle with the button <F6 START>.
- 5 The vehicle must now follow the curve plot of the selected speed profile.

→ In the enlarged cut out of the total diagram (right) a green point represents the current actual value of the vehicle. The actual value should move along the display blue line. In the total diagram (left) a line is shown which represents the part of the diagram which is currently being shown.

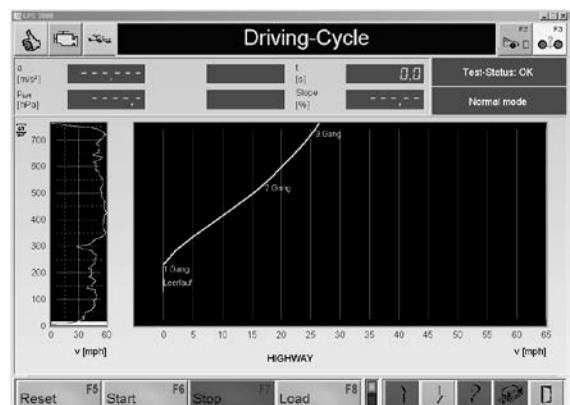

- 6 The driving cycle can be terminated with the button <F7 STOP>.
- 7 The driving cycle is reset to the beginning with the button <F5 RESET>.

Evaluation / Data Logging

- 1 Use the button <F8 EVALUATION>.
→ The following screen appears:

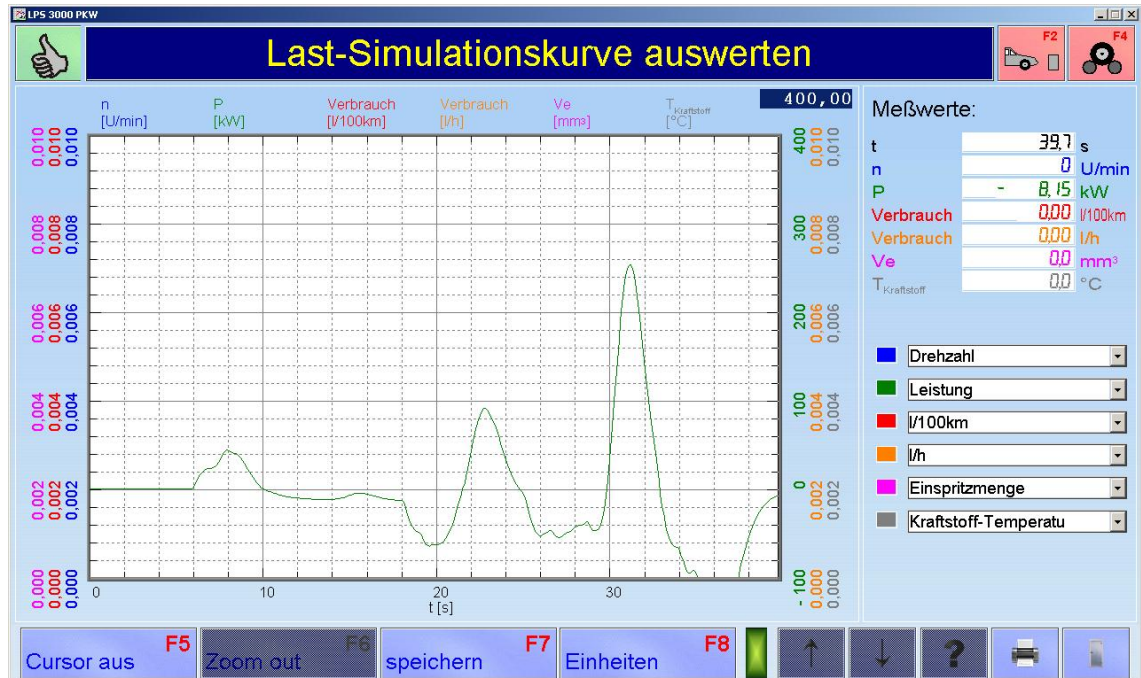

- 2 Use the drop-down menus on the right-hand side to select and save up to six test values per diagram. The number of diagrams which can be saved is not limited.
- 3 Exit the measurement screen with <ESC>.

Scaling the Power and Load Simulation Graphs

The Power and Load Simulation graphs can be manually scaled as follows:

- 1 Double-click the upper left- or right-hand corner of the diagram.
→ An entry field opens.
- 2 Enter the desired scaling value.
- 3 Confirm with RETURN or ENTER.



The Power values [kW] are scaled using the left-hand x-axis, the additional test values using the right-hand x-axis.



Zoom function

- 1 Press and hold left hand mouse key.
 - 2 Frame the desired cutout in the diagram.
 - 3 Release the left hand mouse key.
- The diagram cutout will be enlarged by a maximum factor of 5.
- 4 Use the <F6 ZOOM OUT> key to reduce the original picture size again step by step.

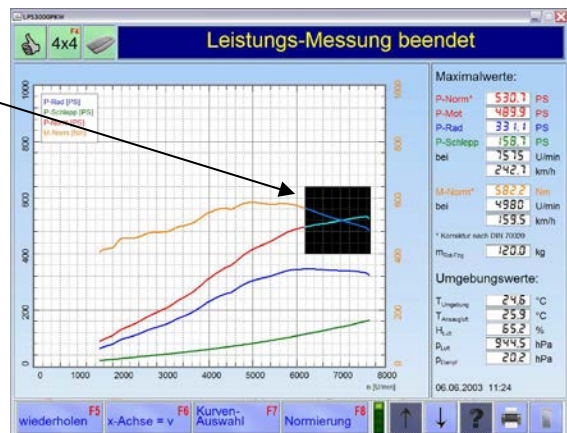

Cursor function

- 1 Press the button <F5 CURSOR>. The cursor is blended in.
- 2 Press and hold left hand mouse key.
- 3 Move the cursor to the desired diagram point.
→ The measurement values are shown in the right –hand column.
- 4 Use the <F5 CURSOR OFF> to blend out the cursor.

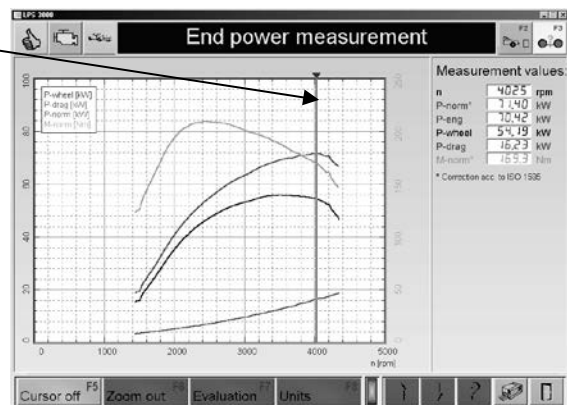

Insert comment

- 1 Press the right hand mouse key. A window opens.
- 2 Enter comment.
- 3 Confirm with <RETURN> .
- 4 Press and hold right hand mouse key to move the comment.

Delete comment

- 1 Select the desired comment with the right hand mouse key.
- 2 Delete comment with .
- 3 Confirm with <RETURN>.

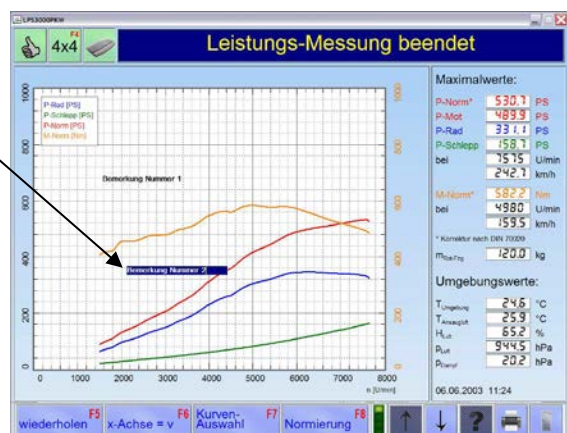

Up to 5 comments with a max. of 40 characters can be inserted into the diagram.

Store

- 1 Use the button <F5 STORE>.
 - The following screen appears:
- 2 Input the vehicle data and information in the entry boxes.
- 3 Use the button <F8 COMPLETE>.
 - The measurement is stored.



The inserted comments are also stored in the database.

Print

- 1 Use the button <PRINT> or key <F12>.
 - The following screen appears:
- 2 Enter the vehicle data and information in the input boxes.
- 3 Using <MEASUREMENT DATA TABLE > an additional, tabular print out of the measurement data can be selected. Enter the increment.
- 4 Select the desired measurement data with the <, <<, >, >> buttons.
 - <<, >>: Select all
 - <, >: Select individual
- 5 Use the button <F8 COMPLETE>.
 - The measurement is printed out.

10.1.2 Constant Traction

A pre-set traction value activates the eddy-current brake immediately which maintains a constant traction for the duration of the measurement.

The values to be set are oriented on

- the model and size of the test vehicle
- and on the desired inclination angle.

A steady incline (sloping surface) is simulated in this mode. It can be used, for example, to run the engine of the test vehicle up to operating temperature. The higher the value entered for the traction the larger the angle of inclination α . The simulated slope can be driven in any gear or speed. The eddy current brake effectiveness remains constant at all speeds.

- 1 Position the vehicle on the dyno and fix it.
- 2 Call up the menu LOAD SIMULATION and then the menu point CONSTANT TRACTION

⇒ The following screen appears:

- 3 Enter the target value of the traction F -Target using the digit keys.
 - 4 Use the button <F8 CONTINUE>.
- ⇒ The measurement screen appears.

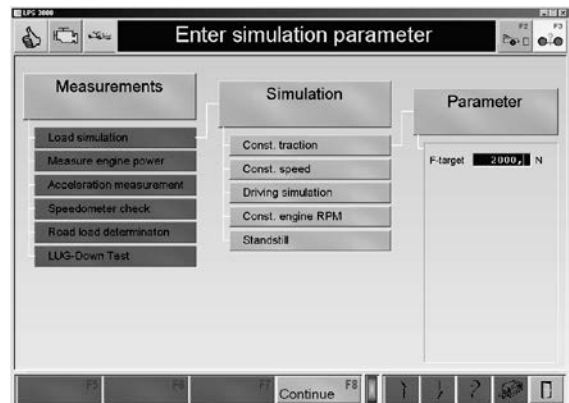

- 5 Start the measurement.
- 6 Use the button <F6> to start or stop the graphic recording of the measurement.



With 4-wheel drive vehicles the traction target value is divided between front and rear (depending on the vehicle-specific distribution of forces).

Example

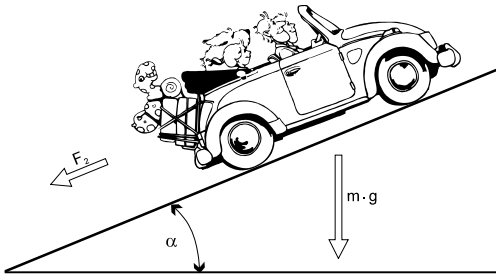

Calculation of the traction F_{st}

$$F_{st} = m \cdot g \cdot \sin \alpha$$

Calculation of the climbing power P_{st}

$$P_{st} = m \cdot g \cdot \sin \alpha \cdot v / 3600$$

with $v = \text{km/h}$ and the following values:

- Vehicle weight $m = 1500 \text{ kg}$
- Angle of inclination $\alpha = 9^\circ$
- Speed $v = 100 \text{ km/h}$
- Acceleration due to gravity $g = 9,81 \text{ m/s}^2$

the result is:

- $= 2302 \text{ N}$ and $P_{st} = 64 \text{ kW} = 89 \text{ PS}$

10.1.3 Constant Speed

With the operating mode *Constant Speed* the dyno is regulated in such a way that the driving speed remains constant independent from the traction (from low to full throttle) created by the vehicle, i.e. only the the speed which was pre-set can be driven. Only the eddy current brake effectiveness increases up to full throttle but not the speed.

- 1 Position the vehicle on the dyno and fix it.
- 2 Call up the menu LOAD SIMULATION and then the menu point CONSTANT SPEED.
→ The following screen appears:
- 3 Enter the target value of the speed v -target into the entry box via the digit keys.
- 4 Use the button <F8 CONTINUE>.
→ The measurement screen appears.

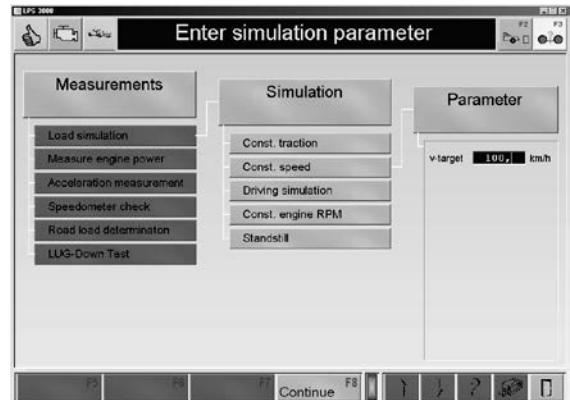

The entered speed must be higher than 7 km/h.

- 5 Start the measurement.
- 6 Use the button <F6> to start or stop the graphic recording of the measurement.



10.1.4 Driving Simulation

The driving simulation reenacts a road drive and/or a certain load which can be set with the drive cycles based on specific drive resistances. The test stand range relates primarily to the maximum speeds of the normal statutory driving cycles from 0 km/h to max. 120 km/h and accelerations in the range of 1 m/s².

Large masses can be simulated during the acceleration with double and single roller dynamometers.

With deceleration, that is coastdown, only the mechanically existing inertia of ca. 250...300 kg (LPS 3000); ca. 280/320 kg (MSR 500) and ca. 700 kg (MSR 1000) act per axle with the double roller set. A higher inertia is not possible with coastdown. In the cycle this results in shorter coastdown times as those given.

With single dynamometers with drive the possibility arises to simulate electrically between 600...700 kg per axle due to existing drives and an acceleration (deceleration) of 1 m/s².

Consequently, drive simulations in the small speed ranges are possible. Another advantage is that because of the drives the inherent dyno losses can be identified and stored at any time. The accuracy of the load is increased significantly.

Influence of Various Factors

The simulation on the roller set is mainly influenced by the factors rolling and flexing resistance. On/in a roller set these can be very different as opposed to the road depending on roller diameter and concept (double or single roller).

Especially at low speeds < 50 km/h the flex and roll resistances of the rollers are larger than the total resistance on the road. Vehicle weight and tire pressure also play a role. These losses cannot be compensated without electric motor.

Consequently, there are large deviations in the driving simulation especially in low speed range with the double roller.

Load Adaption

Using the option "Load Adaption" the street coefficients can be adapted to the rollers. As already mentioned, an adequate adaption can only be done in conjunction with an electric motor. The MAHA MSR dynamometers with drive can conduct this kind of adaption under the above-named limits. However, these do not correspond with the industrial standards of emission dynamometers.

Simulation Model

The operation mode *Drive Simulation (Road load simulation)* is generator- and motor-driven. The vehicle-specific drive resistance characteristic including mass simulation is described by the following simulation model:

$$F = \frac{\text{Koeff A}}{v_{ref}} + \frac{\text{Koeff B} \cdot v}{v_{ref}^2} + \frac{\text{Koeff C} \cdot v^2}{v_{ref}^3} + \frac{\text{Koeff D} \cdot v^{Exp D}}{v_{ref}^{Exp D+1}} + (\text{Masse} - m_{mech}) \frac{dv}{dt} + (\text{Masse} \cdot g \cdot \sin \alpha)$$

F	Tractive force target value
Koeff. A	Rolling resistance coefficient (constant)
Koeff. B	Flexing resistance coefficient (linear)
Koeff. C	Drag coefficient (square with n ≅ 2)
Koeff. D	Drag coefficient (exponential with n being variable)
Exp. D	Exponent D (1 ≤ n ≤ 3, one decimal place)
Masse	Vehicle mass
m _{mech}	Mechanical mass

- V Roller speed
 - dv/dt Roller acceleration
 - g Gravitational acceleration
 - α Gradient angle (\pm)
- (Coefficients A-D refer to a reference speed of 90 km/h.)

- 1 Position the vehicle on the dyno and fix it.
- 2 Open menu LOAD SIMULATION and then menu item DRIVING SIMULATION.
→ The following screen appears:
- 3 Enter the parameters using the number keys or, if available, load them from the database using <F6 DATABASE>.
- 4 Use button <F8 CONTINUE>.



- The measurement screen appears.
- 5 Start the measurement.
 - 6 Use switch button <F6> to start or stop the graphic recording of the measurement.



When testing with electric motors, accelerations of 1...1.2 m/s² are possible with a non-driven axle. This corresponds with a mass of ca. 700 kg per axle.

10.1.5 Constant Engine RPM

With the operating mode *Constant Engine RPM* the dyno is regulated in such a way that the engine RPM remains constant independent from the traction and speed created by the vehicle. The pre-selected target value (n -target) is regulated independent from the traction created by the vehicle up to the max. dyno motor capacity.

- 1 Position the vehicle on the dyno and fix it.
- 2 Call up the menu LOAD SIMULATION and then the menu item CONSTANT ENGINE RPM.
→ The following screen appears:
- 3 Enter the target value of the engine RPM n -target via the digit keys.
- 4 Use the button <F8 CONTINUE>.
→ The following screen appears

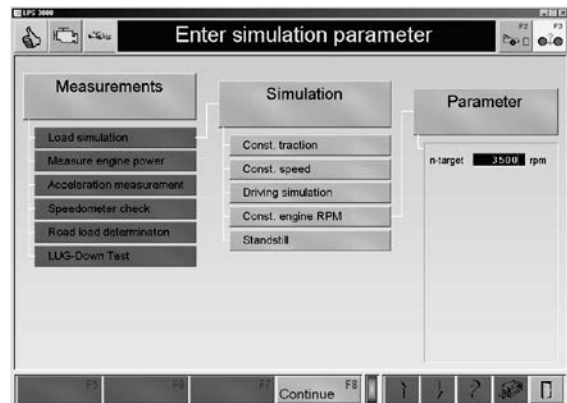

- 5 Start the measurement.
- 6 Use the button <F6> to start or stop the graphic recording of the measurement.



10.1.6 Standstill

This menu point activates the deceleration of the roller set with a defined torque of the eddy current brake.

10.1.7 Drive Dyno

Function "Drive Dyno" requires that you enter a PIN code. The maximum target speed is approx. 200 km/h (depends on the vehicle's driving resistance).



Default PIN code setting: **9864**

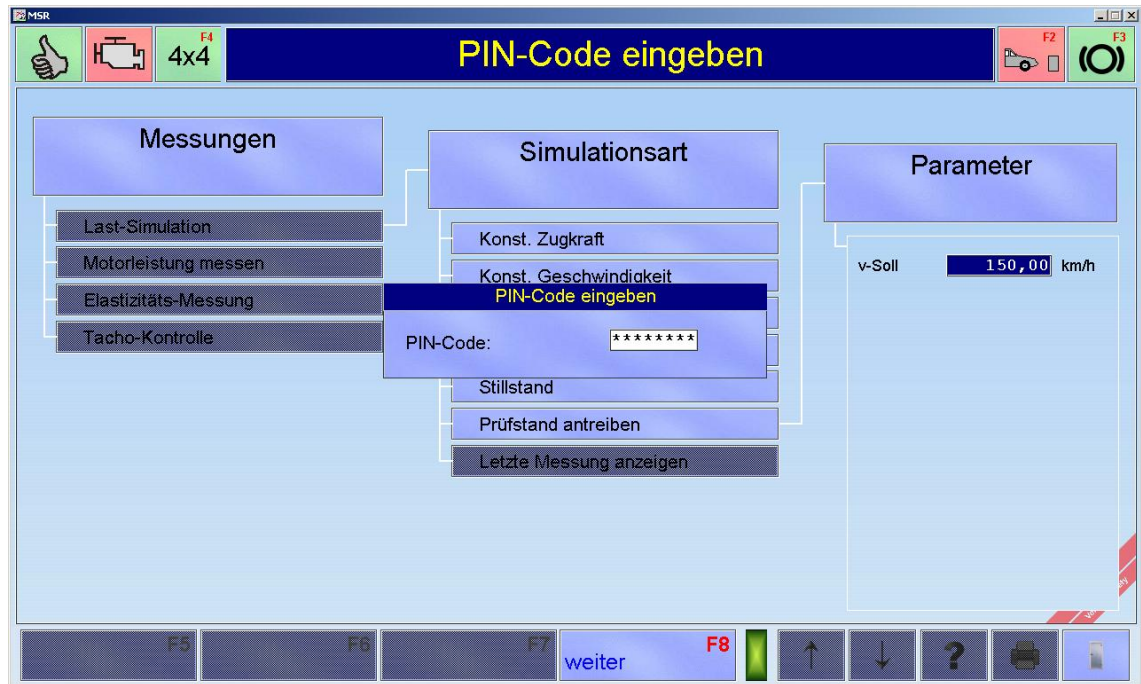

10.2 Measure Engine Power

The vehicle's engine power is measured using this menu point. After selecting this menu point the following selection appears. Select the individual menu points using the cursor keys or the mouse. The menu points are explained below.

- Continuous measurement
- Discrete measurement
- Display last measurement

10.2.1 Display Last Measurement

If the last conducted measurement is not stored and the measurement menu exited, use the item "Display last measurement" to view the measurement again. When exiting the LPS program the temporary storage (or the last measurement conducted) is deleted.



Only active with continuous and discrete measurements!

10.2.2 Continuous Measurement

The max. power is determined during a continuous measurement and the engine power is calculated according to DIN 70020, EWG 80/1269, ISO 1585, SAE J1349 or JIS D1001 ECE, DIN, EWG or ISO (Optional), depending on which setting has been selected in category "Power Correction". The curves for wheel, drag and engine performance are displayed graphically. If air pressure and temperature have been taken into consideration (measured) the engine performance is displayed as standard performance.

- 1 Position the vehicle on the dyno and fix it.
- 2 Open menu MEASURE ENGINE POWER and then menu item CONTINUOUS MEASUREMENT.
→ The following screen appears:

- 3 Select the vehicle data or, if available, load these from the database with <F6 DATABASE>.
- 4 Use the button <F8 CONTINUE>.
- 5 Select the RPM source or the RPM sensor and the appropriate box.
- 6 Use the button <F8 CONTINUE>.

- 7 Accelerate the vehicle gently but continuously up to the second to last gear. As soon as the start speed is reached, the analog display changes to green.
- 8 Then accelerate to full throttle. Pay attention during the shifting phase that the vehicle is not accelerated past 50 km/h otherwise the test will begin before the test gear has been reached.
- 9 Shortly before the max. RPM has been reached disengage the clutch and release the gas pedal.



Use the button <F6 LOAD> to load stored measurements and display in the background. A max. of 3 additional curves can be placed in the background.

- 10 After a successful measurement the engine power and torque are displayed (if an RPM signal is available).

The engine power accrues from the wheel power plus the drag power, which is automatically determined after the clutch is disengaged.

- 11 To evaluate the measurement, see section "*Identical Functions*" and section "*Performance curves*".

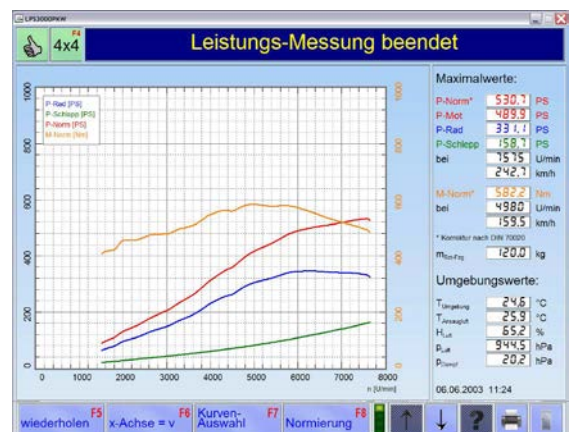

Continuous Measurement with Automatic Transmission and Converter Slip Measurement

- 1 Position the vehicle on the dyno and fix it.
- 2 Open menu MEASURE ENGINE POWER and then menu item CONTINUOUS MEASUREMENT.
- 3 Select the vehicle data, or, if available, load them from the database with <F6 DATABASE>.
- 4 Use the button <F8 CONTINUE>.



For automatic transmissions with torque converter lock-up clutches a value of 0.0 % must be entered if using manual entry.

- 5 Select the RPM source or the RPM sensor and the appropriate box.
- 6 Use the button <F8 CONTINUE>.



The driving trial makes no sense for automatic transmission vehicles without torque converter lock-up clutches, because the engine RPM deviates due to the converter slip.

When accelerating pay attention that the vehicle's "Kick-Down" is not triggered. If this is the case, the test must be cancelled and repeated.

- 7 Accelerate the vehicle in the test gear (next to last gear) until the max. RPM is reached.
- 8 Slowly reduce the throttle once the max. RPM is reached until the message appears "Shift gears and accelerate vehicle to XXX km/h. When this message appears, shift to the last gear and accelerate to the target speed (the previously reached speed + 10%) .
- 9 Then switch to position N and release the throttle.
The message "Shift to position N" appears and shortly thereafter "Let vehicle coast down".
Let the vehicle coast down to start speed while in gear position N.



The test gear must always be the next to the last gear. The measurement starts after a preset start speed has been exceeded, which is normally set at 50 km/h for Car dynos.

Converter slip measurement

- 10 Accelerate the vehicle in the test gear (next to last gear) again to the target speed.
The message line shows the message "Accelerate vehicle to XXX km/h " .
- 11 When the target speed has been reached, release the throttle and let the vehicle coast down to standstill in test gear (not neutral).
- 12 After successful measurement, the engine power, wheel power, drag power and torque (if an RPM signal is available) is shown.
- 13 To evaluate the measurement, see sections "*Identical Functions*" and "*Performance curves*".



The converter slip appears only on the printout, not on the measurement screen.



If the vehicle shifts up at the end of the measurement, this section of the diagram will be removed later. Instead, the software compares the ratio between engine rpm and speed.

10.2.3 Discrete Measurement

Discrete power measurement makes it possible to approach pre-defined points and hold them for a specified time as a function of the speed or RPM. These target points must be set before testing begins.

The **Start- and End speeds** or RPM as well as the **test increments and hold time** are entered by the inspector.

Hold time is defined as the length of time which the pre-set approached RPM and/or speed is held constant. The hold time assures a stable test point so that for example enough time is left for a fuel consumption test to be done.

The **Start-Hold time** eases the regulation procedure. More accurate test results are supplied for turbo-charged engines, whose charger often has a delayed reaction.

- 1 Position the vehicle on the dyno and fix it.
- 2 Call up the menu MEASURE ENGINE POWER and then the menu point DISCRETE MEASUREMENT .
→ The following screen appears:
- 3 Select the measurement type and enter the parameter via the digit keys into the entry boxes.
- 4 Use the button <F8 CONTINUE>.
- 5 Select the vehicle data or, if available, load these from the database with <F6 DATA-BASE>.
- 6 Use the button <F8 CONTINUE>.
- 7 Select the RPM source or RPM sensor and the appropriate box.
- 8 Use the button <F8 CONTINUE>.

- 9 Accelerate slowly and consistently up to start speed.
- 10 Give full throttle when the Start speed is reached.
The dyno starts recording measurement data. The measurement should be done without shifting in the next to last or last gear.



Use the button <F6 LOAD> to load stored measurements and display in the background. A max. of 3 additional curves can be placed in the background.

- 11 With the throttle fully depressed the first set measurement point is approached. The eddy-current brake of the roller set maintains the vehicle or RPM speed about 5 sec. (i.e. according to the set holding time) and stores the measurement value of this point.
- 12 The brake is then released and the next measurement point is approached. The inspector maintains full throttle during the entire test time.
- 13 After all measurement have been taken, the information line at the bottom of the screen indicates to the inspector that the clutch can be released: "Press clutch".
- 14 To evaluate the measurement, see sections "*Identical Functions*" and "*Performance curves*".

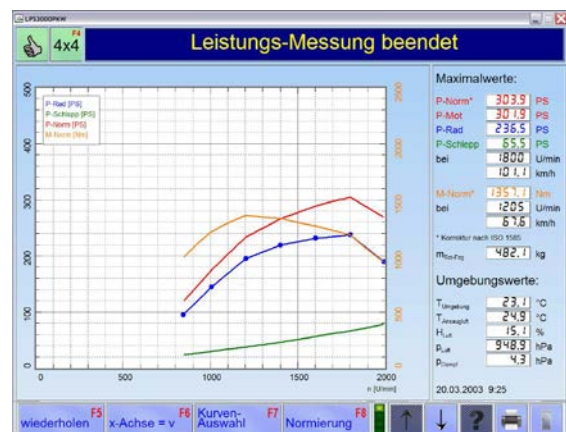

10.3 Engine Flexibility Test

The engine flexibility can be checked using this menu point. Once the flexibility test has been called up the vehicle mass and Road Load must be entered as in the driving simulation test. Enter the start and finish speed of the test. Confirm using the <★> or <Return> key and then the test can begin.

- 1 Position the vehicle on the dyno and fix it.
- 2 Call up the menu FLEXIBILITY MEASUREMENT.
→ Following screen appears:
- 3 Enter the parameter in the boxes using the digit keys or if available, load these from the database with the <F6 DATABASE> key.
- 4 Use the button <F8 CONTINUE>.

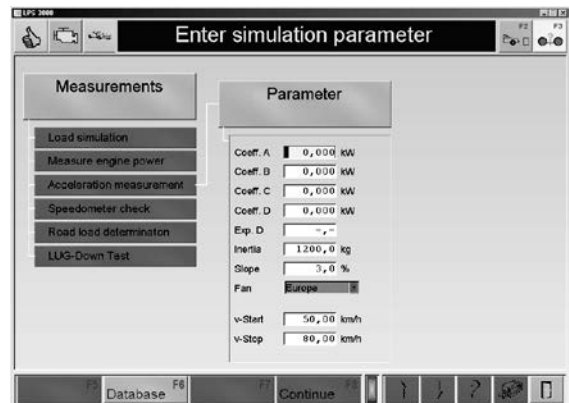

Use the cursor keys <↓> and <↑> to change between the values. Delete erroneously entered characters using the <BACKSPACE> key. Delete a complete box with the <DELETE> key.

- 5 Drive in desired gear and before the start speed is reached, apply full throttle. The test stand starts recording the time.
- 6 The duration of the measurement and the measurement value are displayed.

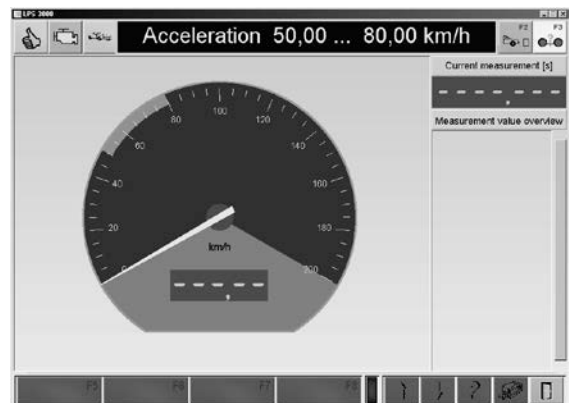

10.4 Speedometer Check

Use this menu point to test the vehicle's speedometer. The following functions can be checked.

- Vehicle speed
- Mileage

10.4.1 Vehicle Speed

Ten freely selectable speedometer target speeds can be entered using this menu point. Each one can be approached, one after another. A basic setting is done at dyno configuration.

- 1 Position the vehicle on the dyno and fix it.
 - 2 Call up the menu SPEEDOMETER TEST and then the menu point VEHICLE SPEED.
→ The following screen appears:
 - 3 Use the key <F6 PROCESS> to change the target speeds.
The value **v-act** shows the current speed of the vehicle on the rollers. The target speed **v-speed** must be approached with the vehicle speedometer.
 - 4 Use the button <F8 CONTINUE>.
 - 5 Accelerate the vehicle to the target speed. Base it on the vehicle speedometer.
 - 6 If the speed is held constant for 3 seconds, the value is automatically taken over. Otherwise store the measurement value with <F8 CONFIRM>.
- The display jumps to the next target speed.
- 7 Repeat the test for each target speed.

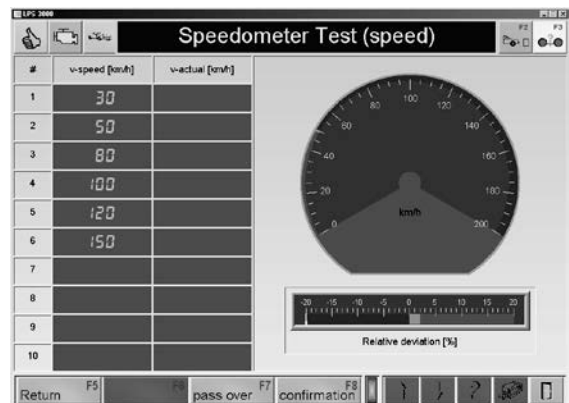
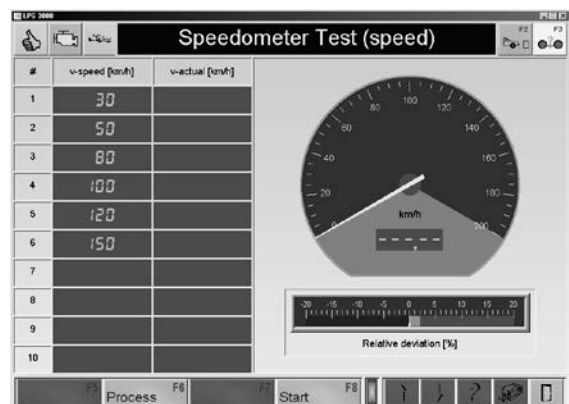

Use the <F5 RETURN> to jump back to the previous target speed.
Use the <F7 PASS OVER> key to jump to the next target speed.

- 8 When the final measurement has been completed a tabular listing of the target and actual speeds will appear as well as a graphic display of the measurement values with the relative and absolute deviation.
- 9 Use the button <PRINT> or <F12> to start a print out of the measurement.
- 10 Use <F5 REPEAT> to repeat a measurement.

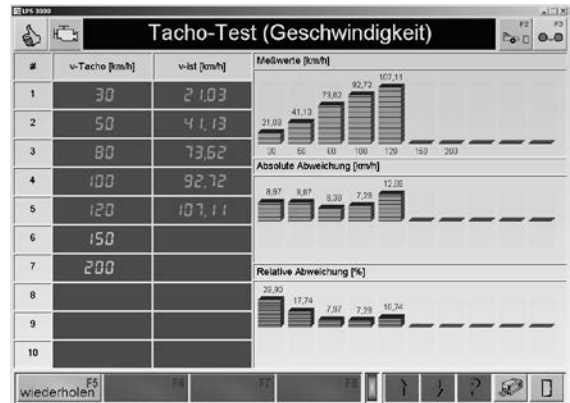

<F6 PROCESS>:

- 1 Change the target speed with the digit keys and confirm with <RETURN>.
- 2 Use the cursor keys <↓> and <↑> to change between the values.
- 3 Delete erroneously entered characters using the <BACKSPACE> key. Delete a complete box with the <DELETE> key.
- 4 Store the changes with the <F8 IMPORT> key.

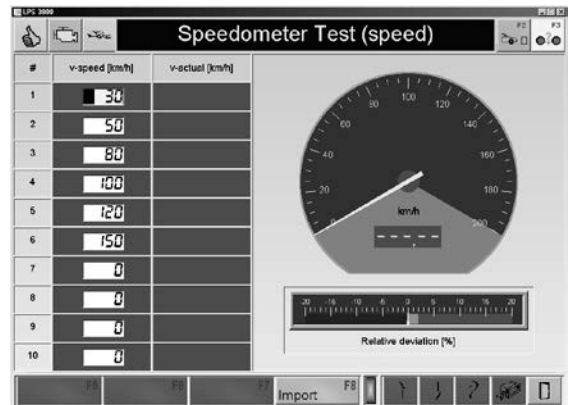

10.4.2 Mileage

- 1 Position the vehicle on the test stand and fix it.
- 2 Call up the menu point SPEEDOMETER CONTROL and then the menu point MILEAGE.
→ The following screen appears:
- 3 Enter the mileage in the box using the digit keys.
- 4 Use the button <F8 CONTINUE>.

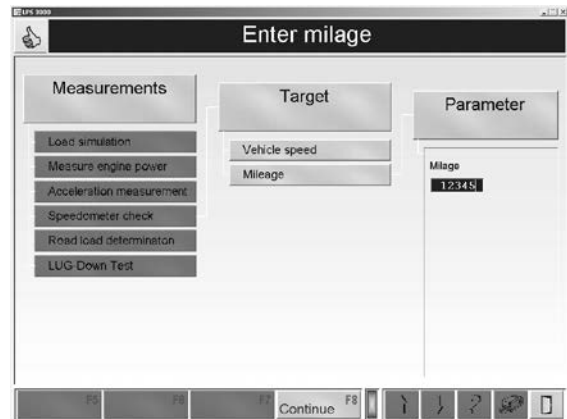

- 5 Drive a random distance with the vehicle on the test stand and compare the values on the vehicle display and on the monitor.
- 6 Use the button <F5 TRIP START> to start the mileage counter test.
- 7 Use the button <F6 TRIP STOP> to stop the mileage counter test.
- 8 Use the button <F7 TRIP RESET> to reset the mileage counter to zero.
- 9 Use <ESC> to end the mileage counter test.



10.5 Load Adaption (Optional)

Use this menu point to do various adaptations; e.g. dyno coefficients can be determined here. The iterative coefficient adaptation can be done based on the following standards, whereby the vehicle must be defined in the vehicle database before doing the adaptation.

→ After the menu point LOAD ADAPTATION the following function selection appears:

- ECE
- SAE J2264

10.5.1 Coefficient Adaption based on ECE

- 1 Position the vehicle on the dyno and fix it.
- 2 Call up the menu LOAD ADAPTION and then the menu item ECE.
→ The following screen appears:
- 3 Enter the parameter in the boxes using the digit keys or, if available, load these from the database with the <F6 DATABASE> key.
- 4 Use the button <F8 CONTINUE>.
→ The measurement screen appears.

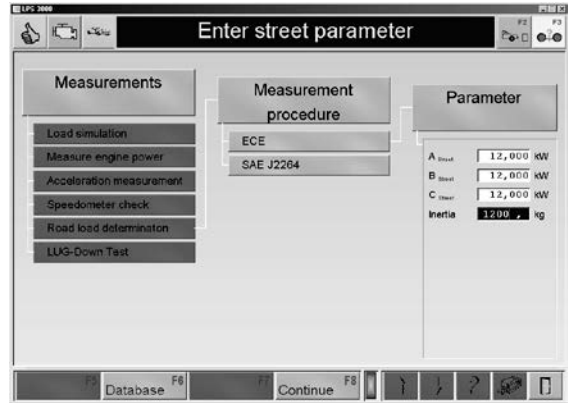

Use the cursor keys <↓> and <↑> to change between the values. Delete erroneously entered characters using the <BACKSPACE> key. Delete a complete box with the <DELETE> key.

- 5 Accelerate the vehicle up to 110 km/h.
- 6 Once the displayed target speed is reached, the roll out trial is initiated. (release gas and disengage clutch)

The dyno is braked based on the preset simulation model. The actual time (ECE) is measured and displayed at each interval.

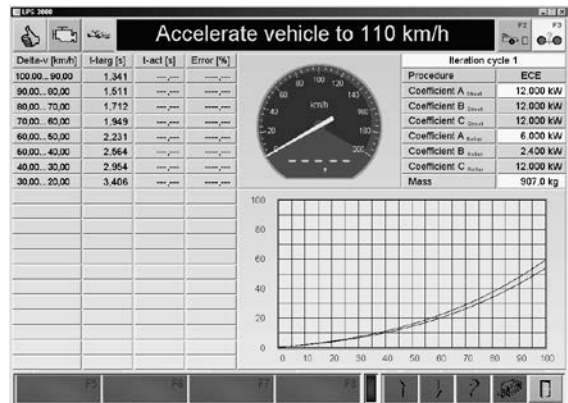

- 7 Repeat steps 5 and 6 until all intervals are in the green range.



With the iterative coefficient adaption based on ECE Standard the evaluation is done per interval. Referring to the target time, the time error is calculated and issued. If the time error is within the tolerance range, the line is showed in green. If the time error is outside of the tolerance range, the line is shown in red. The dyno repeats the coefficient adaption automatically until all set intervals are within the green range and/or the max. set number of runs (standard is 6) are done.

10.5.2 Coefficient Adaption based on SAE J2264

- 1 Position the vehicle on the dyno and fix it.
- 2 Call up the menu LOAD ADAPTION and then the menu item SAE J2264.
→ The following screen appears:
- 3 Enter the parameter in the boxes using the digit keys or
if available, load these from the database with the <F6 DATABASE> key.
- 4 Use the button <F8 CONTINUE>.
→ The measurement screen appears.

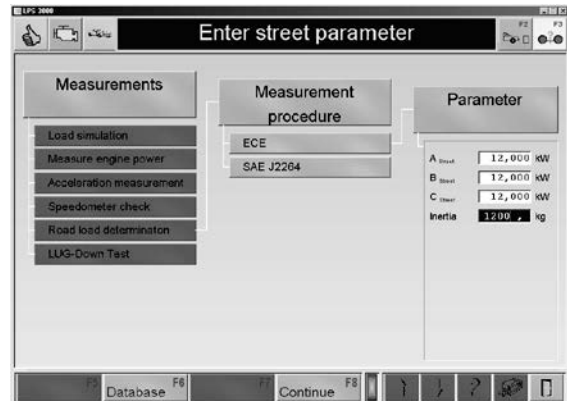

Use the cursor keys <↓> and <↑> to change between the values. Delete erroneously entered characters using the <BACKSPACE> key. Delete a complete box with the <DELETE> key.

- 5 Accelerate the vehicle to 110 km/h.
- 6 Once the displayed target speed is reached, the roll out trial is initiated. (release gas and disengage clutch)

The dyno is braked based on the preset simulation model.

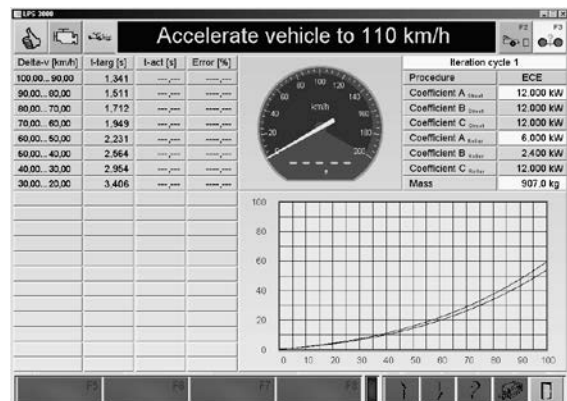

- 7 Repeat steps 5 and 6 until all intervals are in the green range.



With the iterative coefficient adaption based on SAE standard, the evaluation is done only after all intervals of a run have been done. Hereby there is no color evaluation of the Road Load error. The evaluation is displayed however on the test progress bar (green = OK, red = not OK).

10.6 Lug-Down Test (Option)



Country-specific!

Use this option only if a MAHA diesel emission tester is connected to the software and ready for operation.

- 1 Position the vehicle on the dyno and fix it.
- 2 Call up the menu LUG_DOWN TEST .
⇒ The following screen appears:
- 3 Enter the vehicle data.
- 4 Use the button <F8 CONTINUE>.

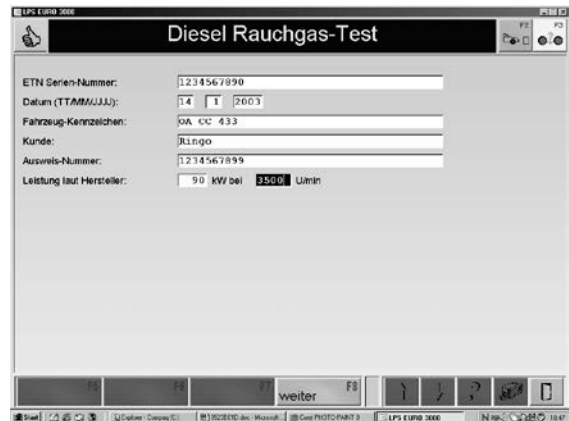

- 5 Determine the RPM with the menu DRIVING TRIAL.
- 6 Do a continuous performance measurement in which the target and actual power as well as the RPM are determined and compared.
- 7 Then the program triggers the MDO LON measurement cell.
⇒ Readiness is then briefly displayed on the screen.
- 8 Now the vehicle must be accelerated to the previously determined max. power (100 %)
⇒ The dyno maintains 100 % power for 5 seconds and the K-value is measured and averaged in this time period.
- 9 Then the dyno regulates to 90 % of the max. power. The dyno maintains 100 % power for 5 seconds and the K-value is measured and averaged in this time period.
- 10 The 3rd test point is correspondingly measured and averaged.
- 11 The results can then be printed out.

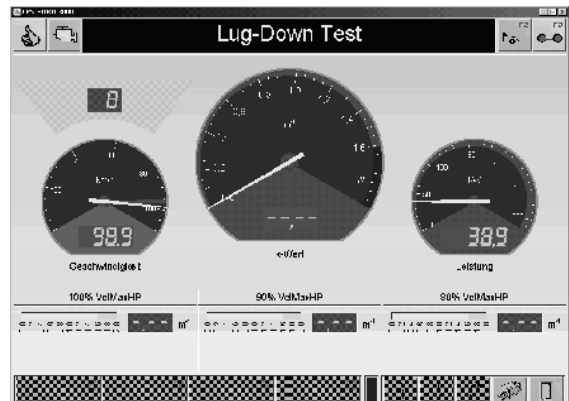

11 Settings

11.1 Database

Various points can be administered using the menu point DATABASE: power curves, time diagrams, vehicle data, load simulation profile and the driving cycle data. Tests conducted can be displayed and printed out using the appropriate menu point. The following describes how data can be entered, changed and deleted in the respective databases.

- 1 Use the menu point DATABASE.
→ Following screen opens:
- 2 Select the desired database.

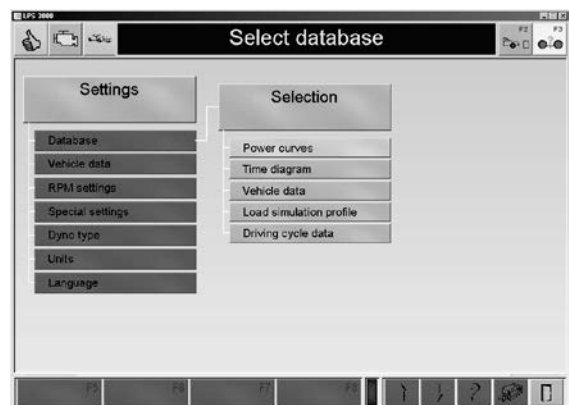

11.1.1 Identical Functions

Button description

Clean Up	F5	• Use this button to remove the data sets from the database via the date
Delete	F6	• Using this button datasets can be removed from the database.
Export	F7	• Using this button, datasets can be exported from the database.
Import	F8	• Using this button datasets can be imported from the database.

Clean Up

Performance Curves and Time Diagram

- 1 Enter the date and confirm with <ENTER>.
- 2 Use <ESC> to exit the window without deleting the datasets.

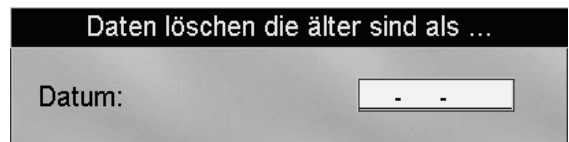

Driving Cycle Data

- 1 To delete the data of the last 7 days, select YES.
- 2 Select NO if you do not want to delete the dataset.

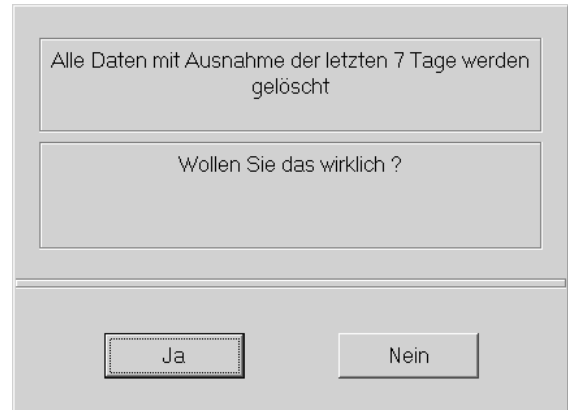

Delete

- 1 Select the desired database.
→ The database Browser appears:
- 2 Select with the cursor keys or mouse.
- 3 To delete a marked dataset, press <F6 DELETE>.



→ Following safety inquiry appears.

- 4 To delete the dataset select YES.
→ The dataset is deleted from the database.

Select NO if the dataset should not be deleted.



Export

- 1 Select the desired database.
→ The Browser database appears:
- 2 Select using the cursor keys or the mouse.
- 3 To export a marked dataset, press <F7 EXPORT>.
→ Following window opens.
- 4 Enter a file name and if necessary select a path.
- 5 Confirm with <STORE>.

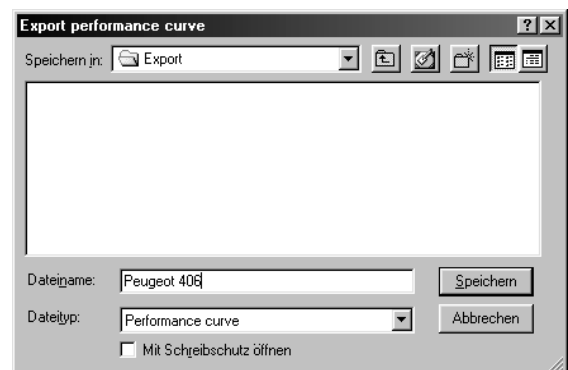



The datasets are stored on the hard disk under C:\MAHA*Dyno Model*\Export\... .

Import

- 1 Select the desired database.
→ The database Browser appears:
- 2 Use the key <F8 IMPORT>.
→ Following window opens.
- 3 Select with the Cursor-keys or the mouse if necessary to change the path.
- 4 Import the dataset with <OPEN>.

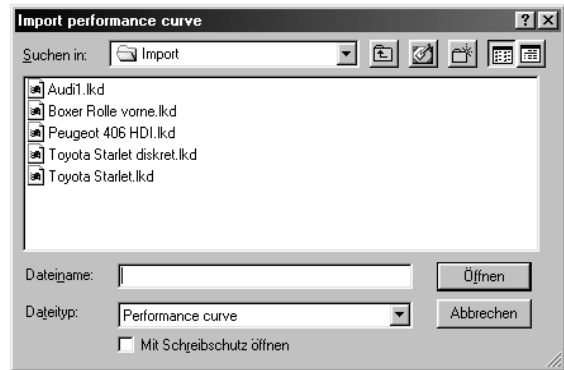

As standard, the datasets are imported from C:\MAHA*Dyno Model*\Import\...

11.1.2 Performance Curves

- 1 Call up the menu DATABASE and then the menu item PERFORMANCE CURVES
→ The database browser appears:
- 2 Select a dataset with the cursor keys or the mouse key.
- 3 Open the dataset by double clicking or pressing the button <ENTER>.
→ The measurement screen appears.

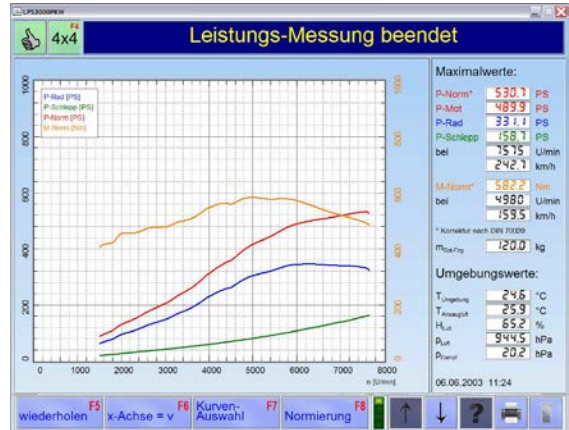

Button Description

LEVEL 1

Repeat	F5
x-Achse=v	F6
Curve selection	F7
Power correction	F8

- Use this button to repeat the measurement.
- Use this button to switch over the display of the x-axis between speed and RPM.
- Use this button switch the display between curve selection and max. value.
- Use this button to select various standard calculations from a list.

LEVEL 2

Cursor	F5
Zoom out	F6
Units	F8

- Use this button to blend the cursor in and out. The cursor can be moved using the mouse key.
- Use this button to display the original picture again, step by step.
- Use this button to change the units.

LEVEL 3

Save	F5
Load	F6
Save in background	F7
Excel Export	F8

- Use this button to store the buttons.
- Use this button to load a stored measurement.
- Use this button to display a loaded measurement in the background.
- Use this button to export power curves as text files.

LEVEL 4

Vehicle-data	F5
RPM-settings	F6
P-drag wizzard	F7
Finish wizzard	F7

- Use this button to display the vehicle data.
- Use this button to display the RPM setting.
- Use this switch button to smooth the power curve (P-drag) by extrapolation and then to store.

Curve Selection

- 1 Use the button <F7 CURVE SELECTION>. → The following screen appears:
- 2 Use the keys 1 to 4 or the appropriate buttons to blend in the individual performance curves.
- 3 Using the keys 5 to 7 or the appropriate buttons a max. of 3 additional measurements (torque and engine power), if loaded, can be blended in and out in the background.
- 4 A max. of 3 additional curves can, if loaded, be blended in or out in the background with the selection boxes or the appropriate buttons.
- 5 With <F7 MAX. VALUES> the max. values are re-displayed.

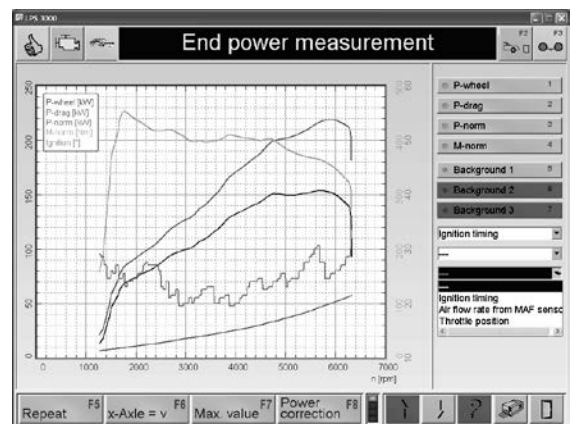
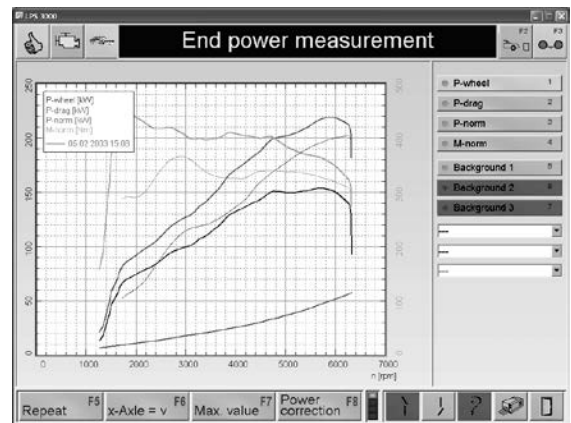
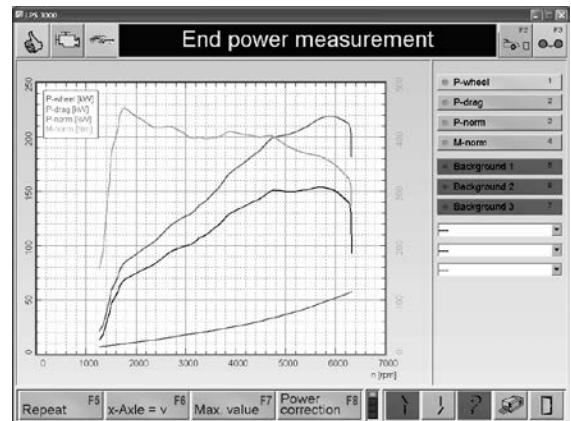



The additional curves can only be displayed when the appropriate sensors and measurement units are connected.

Power Correction

- 1 Use the button <F8 POWER CORRECTION>.
 - The following selection box opens:
- 2 Select the desired engine power projection. The power and torque are calculated and displayed based on the desired power correction.
- 3 Using the keys 5 to 7 or the appropriate buttons a max. of 3 further measurements, if loaded, can be blended in and out in the background. rund ein- und ausgeblendet werden.



Load

- 1 Use the button <F6 LOAD>.
 - The following selection box opens:
- 2 Select where the desired measurement is to be loaded.
 - The database Browser opens:
- 3 Select a dataset with the cursor key or the mouse.
- 4 Open the dataset by double clicking or press the <ENTER> key.

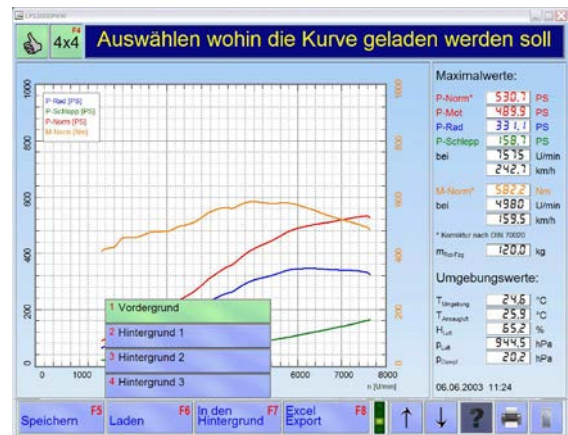

Excel Export

Using this menu item, power curves can be exported as a text file.

- 1 Use the button <F8 EXCEL EXPORT>.
 - The following screen appears:
 - 2 Enter the vehicle data and information in the entry boxes.
 - 3 Use the button <F8 COMPLETE>.
-
- 4 Enter a file name and select, if necessary, a path.
 - 5 Confirm with <STORE>.

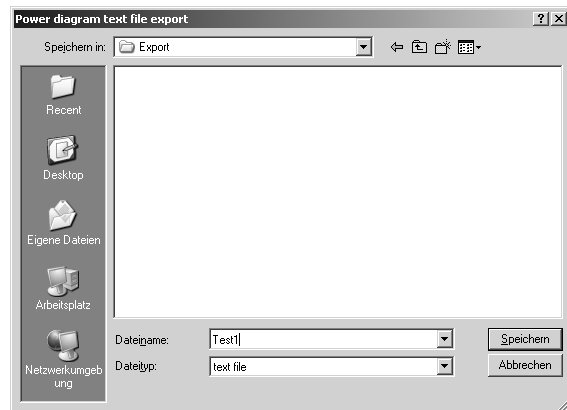
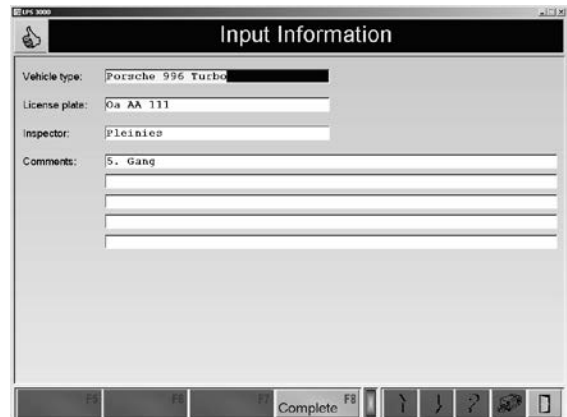

The data records were stored on the hard disk under **C:\MAHA*Dyno Model*\Export\...**

P-Drag Wizard

- 1 Use the button <F7 P-DRAG WIZARD>.
 - The wand is blended in.
- 2 Move the wand with the mouse onto the desired point on the power curve.

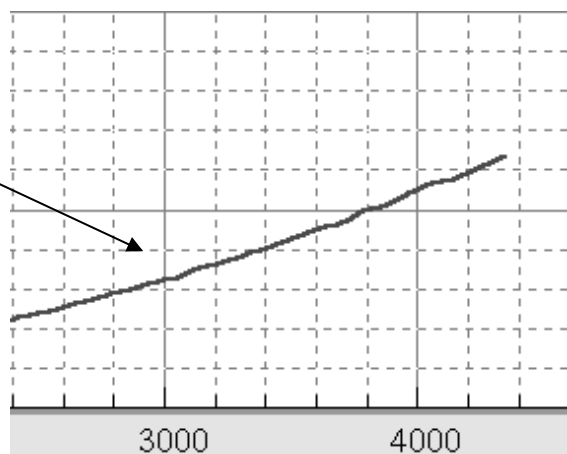

- 3 Press the left hand mouse key.
 → The curve is smoothed by interpolating. The interpolation is only done on the upper half of the curve.

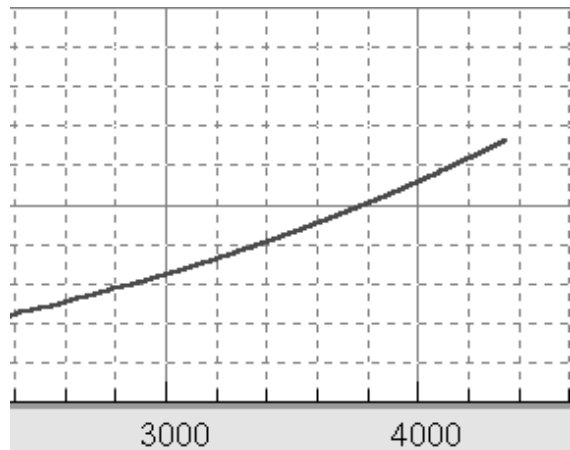

- 4 Use the button <F7 END WIZARD >.
 → The following window appears:
- 5 Select YES to store the changes, if not, select NO.



11.1.3 Time Diagram

- 1 Call up the menu DATABASE and then menu point TIME DIAGRAM
 ⇒ The database Browser appears:
- 2 Select a dataset with the cursor key or the mouse.
- 3 Open the dataset by double clicking or press the <ENTER> key.
 ⇒ The measurement screen appears.

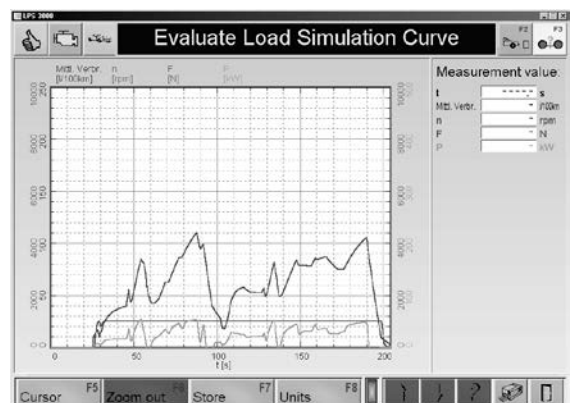

Cursor	F5
Zoom out	F6
Store	F7
Units	F8

- Use this button to blend the cursor in and out. The cursor can be moved using the mouse key.
- Use this button to display the original picture again, step by step, (see paragraph "Zoom-Function" in Chapter "Measurements").
- Use this button to store the vehicle and customer data (see Chapter 6, Paragraph "Identical Functions" and function "Store").
- Use this button to change the units. (see paragraph "Units" in Chapter "Settings").

11.1.4 Vehicle Data

- 1 Call up the menu DATABASE and then the menu point VEHICLE DATA
→ The database browser appears:
- 2 Select a dataset with the cursor key or the mouse.
- 3 Open the dataset by double clicking or press the <ENTER> key.
→ The screen for the load simulation model appears:
- 4 Define the load simulation model.
- 5 Use the button <F8 CONTINUE>.
→ The vehicle data screen appears.
- 6 Select the vehicle data.
- 7 Use <F8 STORE> to store the data.

Calculate ABC-coefficients:

- 1 Use the button <CALCULATE ABC-COEFFICIENTS >
→ Following screen appears.
- 2 Enter mass including driver and fuel and confirm with <ENTER>.
→ The total mass at roll out trial and the share of the rotating mass are calculated and displayed.
- 3 Enter the start and end speed as well as the time interval.
- 4 Store the info with <F8 IMPORT>.

11.1.5 Load simulation profile

Using the menu point LOAD SIMULATION PROFILE the measurement screen and the print out can be set for customer-specific needs.

Create new profile

- 1 Call up the menu DATABASE and then the menu point LOAD SIMULATION PROFILE :
→ The database Browser appears.
- 2 Use the button <F5 NEW>.
→ The screen for the profile settings appears.

The profile setting screen is divided up into the following areas:

- PROFILE NAME
- ANALOG DISPLAY
- DIGITAL DISPLAY
- PRINT OUT SETTING



Analog display

Two analog displays are available.

- 1 Select the measurement values to be displayed from the list.
- 2 Enter the min. and max. values as well as the scaling factor.
- 3 Enter the limit values for the green, yellow and red ranges.
- 4 Use <F6 IMPORT> to display the settings.

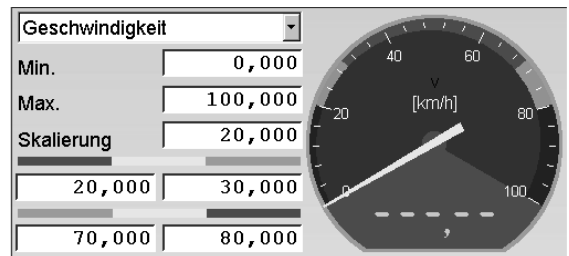

Digital display

There are six digital displays available.

- 1 Select the measurement values to be displayed from the list.



Print out setting

Up to six measurement values can be selected which appear as curves on the print out.

- 1 Select the measurement values to be displayed from the list. Enter the appropriate measurement range.
- 2 Enter the time period for the graphic recording.



Selection list of the measurement values:

- | | | |
|--------------------------|--------------------------------|---------------------------|
| - Speed | - O ₂ | - Simulated inertia |
| - RPM | - NO | - Simulation target value |
| -Traction | - Lambda (Emission tester) | - Simulation actual value |
| - Power | - Turbidity | - Simulation error |
| - Speed FA | - k-value | - Positive simulation |
| - Speed RA | - Fuel quantity | - Negative simulation |
| - Traction FA | - l/100 km | - Max. pos. simulation |
| - Traction RA | - l/h | - Max. neg. simulation |
| - Power FA | - Injection quantity | - Force on vehicle |
| - Power RA | - Average consumption | - Vehicle energy |
| - Acceleration | - Coolant temperature | - Energy from vehicle |
| - Air pressure | - Ignition point | - Energy from vehicle |
| - Intake air temperature | - Fuel pressure | - Road Load |
| - Fuel temperature | - Suction pipe pressure | - Total speed |
| - Ambient temperature | - Air quantity throughput flow | - Angle (FA) |
| - Oil temperature | - Throttle valve position | - Angle (RA) |
| - Humidity | - OBD Lambda (from vehicle) | - Temperature 1...8 |
| - CO | - ISE | - Pressure 1...8 |
| - CO ₂ | - Travel distance | - Analog 1...8 |
| - HC | - Speed | |



The measurement value can only be displayed when the appropriate sensors and measurement devices are connected.

In connection with the analog input module (optional), Analog 1...8 are overwritten with the given designation from the external measurement data of the configuration.

Store Profile

- 1 Enter the name of the profile in the first line of the screen.
- 2 Press the button <F8 STORE>.

Process Profile

- 1 Call up the menu DATABASE and then the menu point LOAD SIMULATION PROFILE:
→ The database browser appears.
- 2 Select a profile with the cursor key or the mouse.
- 3 Open the profile by double clicking or press the <ENTER> key.
→ The screen for the profile setting appears

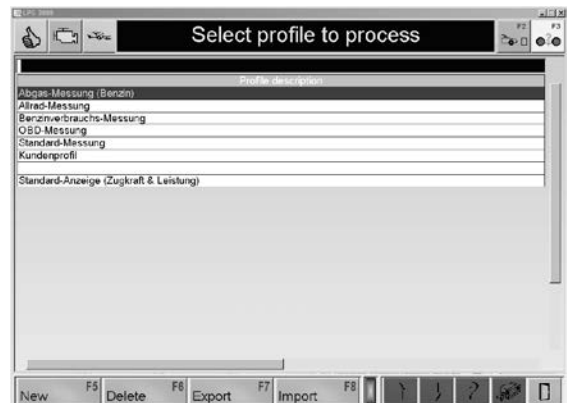

- 4 Enter the changes. Select the boxes and enter the desired values.
- 5 The changes are displayed with <F6 IMPORT>.
- 6 The changes are stored with <F8 STORE>.

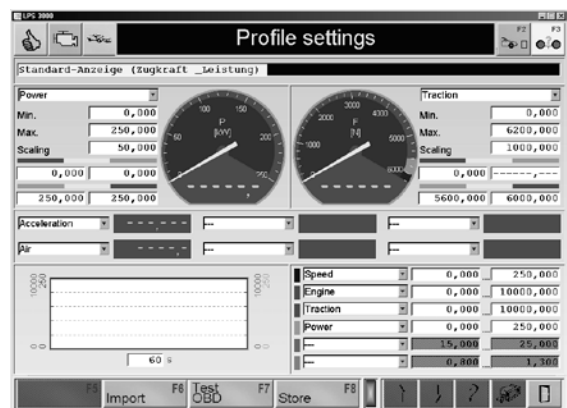

Export Profile

See paragraph "*Identical Functions*", function "*Export*".

Import Profile

See paragraph "*Identical Functions*", function "*Import*".

11.1.6 Driving Cycle Data

- 1 Call up the menu DATABASE and then the menu point DRIVING CYCLE:
→ The database browser appears.
- 2 Select a dataset with the cursor key or the mouse.
- 3 Open the dataset by double clicking or press the <ENTER> key.
→ The measurement screen appears.



11.2 Vehicle Data

Use the menu item VEHICLE DATA to enter and change the vehicle data.

- 1 Use the menu item VEHICLE DATA.
→ A screen opens in which the vehicle data is shown, e.g.:
- 2 Select the vehicle data, or, if available, load these from the database with <F6 DATA-BANK>.
- 3 Store the vehicle data with <F8 IMPORT>.



The selection of the vehicle data is confirmed by the lights illuminating.

Line	Description
Engine type	- Otto /- Diesel / - Wankel
Charging	- None / Mechanical charger (VEH with compressor) - Turbo (air cooled) - Turbo (water cooled)
Transmission	- Manual / - Automatic
Slip	if Automatic transmission: - no slip - measure slip (converter slip) - input
Drive	- Front drive / - Rear drive / - 4 wheel drive
Performance class	10 / 25 / 50 / 100 / 250 / 500 kW
Performance correction	None / DIN / EEC / ISO / JIS / SAE
Additional factors (optional)	- f_m engine factor / - Q_v / P_{VA}
Limit values	If one of these limit values is exceeded a warning message will appear on the screen and the display changes to red: - v_{max} Maximum speed - n_{max} Maximum engine RPM - T_{max} Maximum oil temperature
Rotating mass	- Standard mass (60 kg) - Determine mass (2nd roll out trial with a truck) - Input
Haldex clutch	Improved graphic representation of power curves for vehicles with Haldex drives
Fuel density	Entry of fuel density for consumption measurement; Unit: g/l

11.3 RPM Setting

Using the menu point RPM SETTINGS the oil temperature and engine RPM can be checked and selected.

- 1 Use the menu point RPM SETTINGS.
→ A screen opens in which the motor RPM and oil temperature are shown, e.g.:
- 2 The RPM source or the RPM sensor can, if necessary, be changed. Select the box needed.

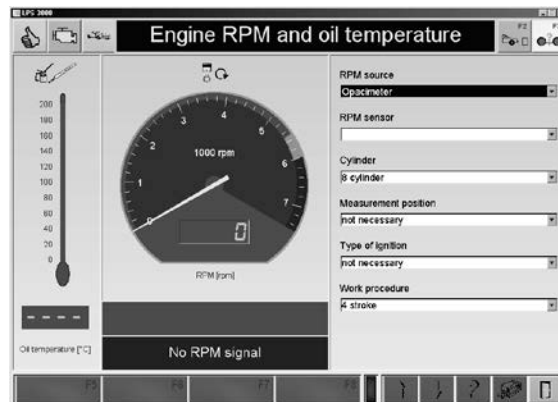

If the *Automatic Selection* point is selected from the list, the dyno automatically recognizes the RPM sensor being used.

RPM source:

- no RPM recording
- Standard LPS RPM Module
- Driving trial
- OBD
- Emission tester
- Opacimeter

Operating system:

- 2 stroke
- 4 stroke
- Wankel

RPM Sensor:

- Trigger tongs
- Licht barrier sensor
- TDC sensor
- Clamp W
- Diagnostic plug
- Rotophon
- Rotophon Mode 2
- Piezo clamp
- Ignition coil clamp 1

Ignition type:

- One spark coil
- Two spark coil

Cylinder:

- 1, 2, 3, 4, 5, 6, 8, 10, 12 cylinder

Measurement position:

- Trigger tongs at the spark plug
- Trigger tongs at the spark plug

11.3.1 Driving Trial

The driving trial enables the vehicle's internal RPM sensor to establish a connection to the driven speed. The roller speed of the dyno vehicle is converted to an RPM. On the basis of this vehicle transmission, the corresponding RPM value can also be shown on the screen of the test which follows.

The RPM value for the driving trial is shown in rot/min. The adjustment RPM selected must be high enough that it can be reached with the next to last gear (test gear / gear transmission close to 1:1)

During the test which follows, the software converts the current speed in an engine RPM. (Please note: The calculated RPM only agrees with the actual RPM of the power measurement when driving with the 'Test gear' .)



The driving trial makes no sense on automatic vehicles without converter lockup, because the engine RPM deviates due to the converter slip.

- 1 Position the vehicle on the dyno and fix it.
- 2 Use the menu point RPM SETTINGS in the main screen.
- 3 Select DRIVING TRIAL from the list.
- 4 Enter the adjustment RPM and confirm with <ENTER>.
- 5 Accelerate the vehicle in test gear up to the pre-set RPM. Pay attention to the vehicle's RPM sensor.
- 6 Hold the RPM constant for a few seconds.
- 7 This RPM is stored.

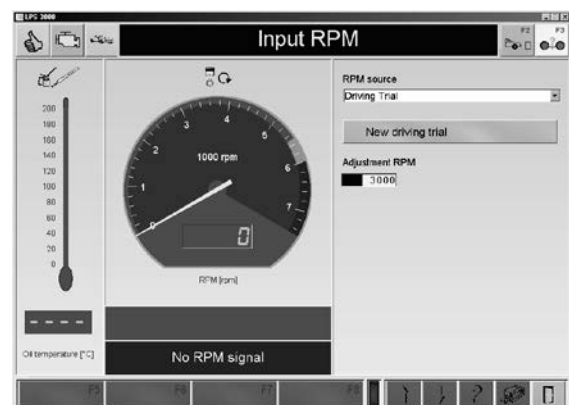

11.4 Special Settings

Use the menu point SPECIAL SETTINGS to change the time period, the sensitivity and the delay for the performance measurement.

- 1 Using the corresponding button , the values can be increased or decreased: <+> bzw. <->.
- 2 Use <F8 IMPORT> to import the settings.
Use <F7 STANDARD> to load the standard settings.

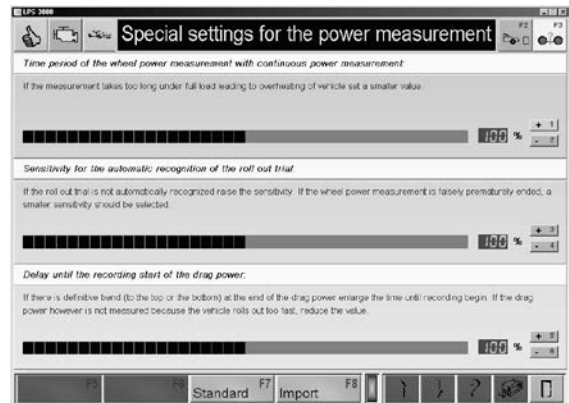

- **Time period of the wheel performance measurement with continuous power measurement**
If the measurement under full load takes too long, this leads to an overheating of the charging air temperature. A smaller value should be set. If the measurement is too fast, no sufficient boost pressure will not build up. The value should therefore be raised.
- **Sensitivity for the automatic recognition of the roll out trial**
If the roll out trial is not automatically recognized, the sensitivity should be raised. If the wheel power measurement is then erroneously terminated too early, a smaller sensitivity should be selected.
- **Delay until the drag power recording begins**
If a clear bend is seen at the end of the drag power (up and then down) , the time until the recording begins should be increased. If the drag power could not be measured because the vehicle roll out too fast, the value should be decreased.
- **Speed at which the measurement begins and the roll out trial ends**
If it is not possible to go into the test gear before the power measurement starts, the values should be increased. If, however, the roll out trial is too short meaning that no drag power is measured, the value can be decreased.

11.5 Select Dyno Type

Use the menu point SELECT DYNO TYPE to set the dyno type.

- 1 To change the dyno type, use the menu point SELECT DYNO TYPE.
→ A selection box opens which shows the available dyno types.
- 2 Select the desired dyno type.
→ The dyno type is changed and the program started anew.



11.6 Units

Use the menu item UNITS to select among Power in PS, SI, Us or GB units.

- 1 In order to change the units, use the menu item UNITS.
→ A selection box opens in which the available unit models are shown. e.g.:
- 2 Select the unit model needed.



Variable	SI-Units	Power in PS	US Units	Brit. Units
Power	kW	PS	HP	BHP
Engine speed	R/min	R/min	rpm	rpm
Speed	km/h	km/h	mph	mph
Torque	Nm	Nm	lbf.ft	lbf.ft
Meas. unit	kg	kg	lb	lb
Tractive force	kN	kN	lbf	lbf
Temperature	°C	°C	F	F
Air pressure	hPa	hPa	hPa	hPa
Humidity	%	%	%	%

11.7 Language

The language can be changed using the menu point LANGUAGE.

- 1 To change the language, use the menu point LANGUAGE.
→ A selection box opens in which the available languages are shown, e.g.:
- 2 Select the language needed.
- 3 Store the changes with <F8 IMPORT>.

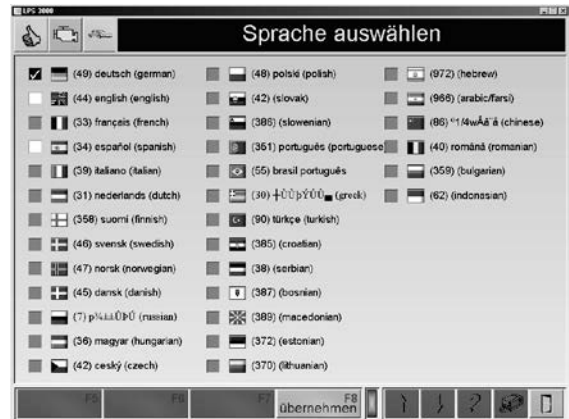

11.8 Device / Interfaces

Use the menu item DEVICES / INTERFACES to activate/deactivate the externally connected devices. In addition, measurement of the refrigerant temperature via OBD can be optionally selected.

- 1 Use menu item DEVICE / INTERFACES.
→ A screen opens in which the external devices are activated/deactivated and temperature measurement via OBD can be selected.
- 2 Select the checkboxes as required.
- 3 Use <F8 IMPORT> to accept the settings.



11.8.1 OBD Settings (Optional)

Use the menu point OBD settings to select and display the measurement data. The measurement data supplied by the diagnostic interface vary depending on the vehicle manufacturer.

- 1 Use the menu point OBD-SETTINGS.
⇒ The following window opens.
- 2 Connect the OBD plug with the diagnostic interface.
- 3 Start the engine and let it run in idle.
- 4 Confirm with <COMPLETED>.



After communication has been set up, the OBD symbol appears green in the status line. Following screen appears:

- 5 Select the desired measurement values for Channel 1 to 4 from the list.
- 6 Use <F8 IMPORT> to accept the settings.

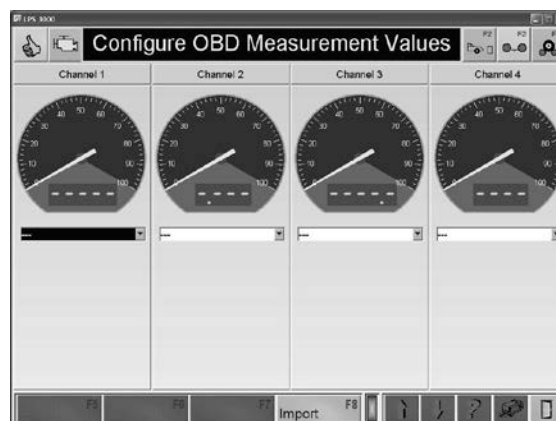

If the communication cannot be set up the first time, wait approx. 10 seconds and repeat the procedure. switch off the ignition and separate the reading device from the diagnostic interface. Then repeat step 1 – 4.

12 Diagnosis / Service

12.1 Dyno Status

After calling up this menu point, a screen appears which displays, e.g. the set operating mode, the rotation direction, the active axle, various regulator and fan target values as well as malfunctions/warnings.

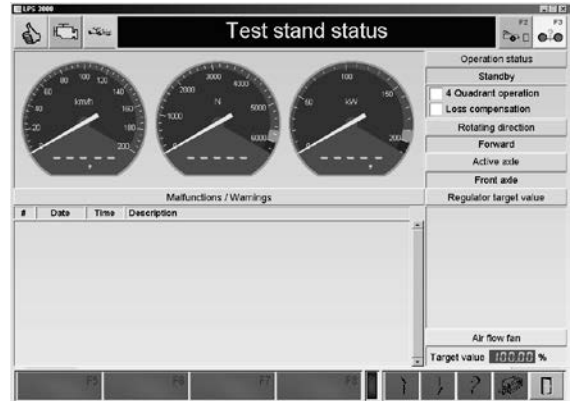

12.2 Driver's Aid Setup (Optional)

Administer the driver's aid using this menu point.

After calling up this menu point the following screen appears:

Select the desired option.

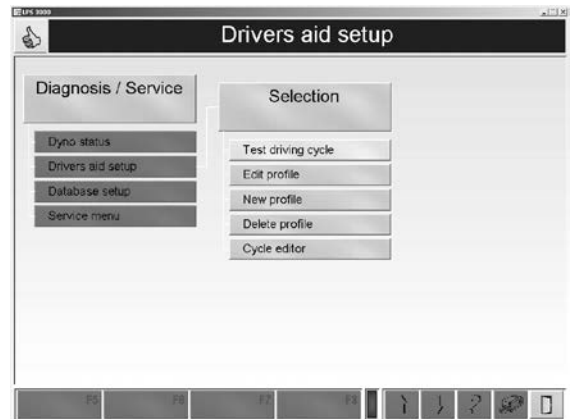

12.2.1 Test Driving Cycle

Using the button *Test Driving Cycle* to do a speed profile with fixed time and speed curves. The test driver need only follow the curve plotting displayed on the screen.

The various standard cycles are in the directory *Cycles*. These cycles can be loaded using the button <F8 LOAD> .

LEVEL 1

- 1 Call up the menu <TEST CYCLE> .
→ The following screen appears:
- 2 Use the button <F8 LOAD>

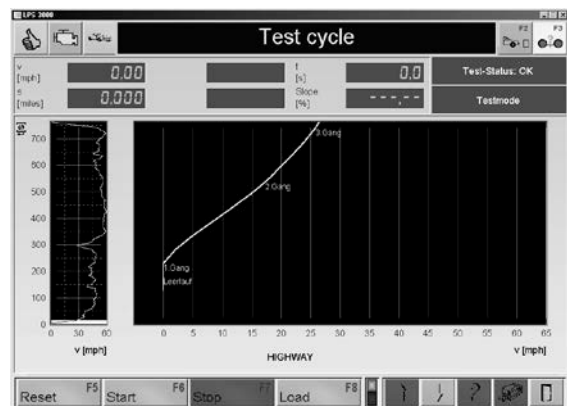

- The selection screen appears.
- 3 Select the driving cycle with the cursor keys or the mouse and load it with <OPEN>.

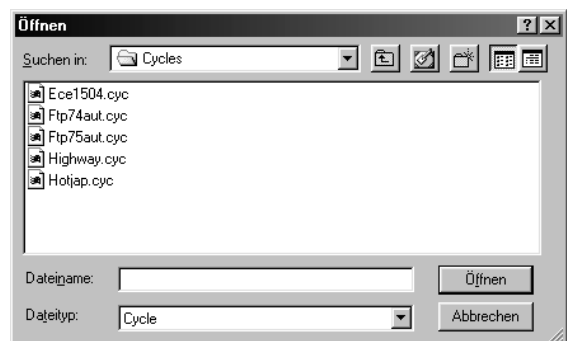

- 4 Start the driving cycle with the button <F6 START>.
- 5 Now the vehicle must drive the selected curve of the speed profile.

→ A green point represents the current value of the vehicle in the enlarged cut out of the total diagram. The actual value should move along the displayed blue line. A line in the total diagram (left) shows which cut out of the diagram is currently displayed.

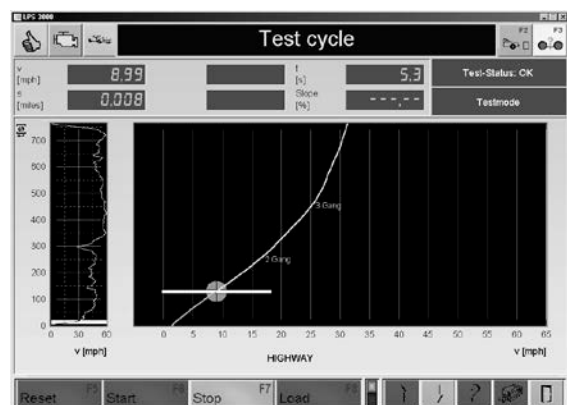

- 6 The driving cycle can be terminated with the button <F7 STOP>.
- 7 Using the button <F5 RESET> the driving cycle is reset to the beginning.

LEVEL 2

- A pull up menu open using the button <F5 SELECT PROFILE> .

Select the desired profile.
The screen is displayed with the selected profile.

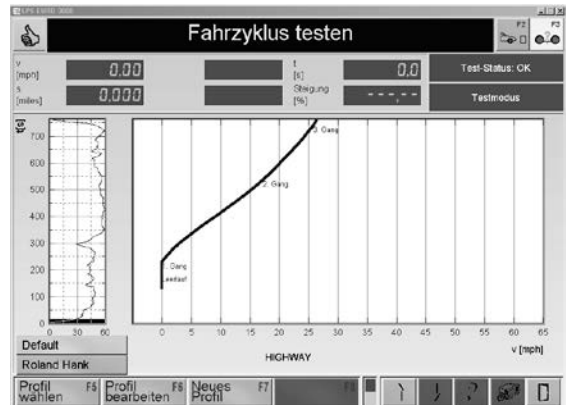

12.2.2 Edit Profile



To edit a new profile, it must first be created with the menu point NEW PROFILE.

- Use the button <F6 WORK PROFILE> to set the colors of the profile.

Double click the desired box and the color selection window appears.

Select the desired color and confirm with OK.

Use <F5 STORE> to import the settings.



12.2.3 New Profile

- Use the button <F7 NEW PROFILE> to create a new profile.

Enter the name and confirm with <ENTER>.



12.2.4 Delete Profile

A profile can be deleted via the menu point DELETE PROFILE .



There is no security inquiry when deleting and there is no possibility to restore the profile!

12.3 Backup/Restore Database

12.3.1 Backup Database

- 1 Enter the file name and if necessary, select a path.
- 2 Confirm with <STORE>

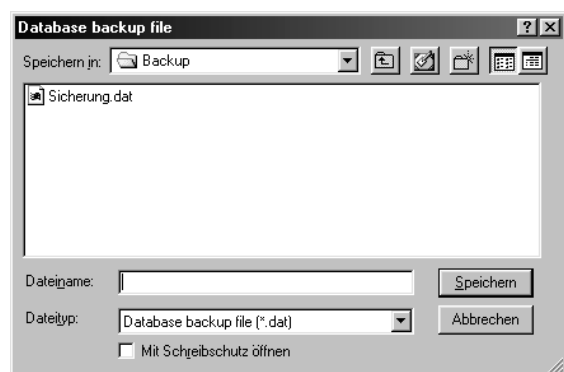

The database backup file is stored on the hard disk under C:\MAHA\Dyno Model\Backup\...

12.3.2 Restore Database

- 1 Select a database backup file.
- 2 Confirm with <OPEN>

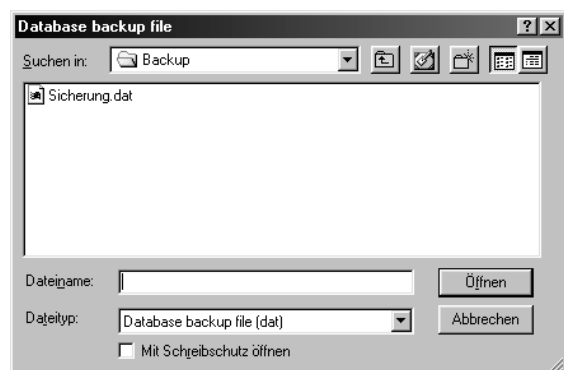

The database backup file is opened from C:\MAHA\Dyno Model\Backup\... as standard path.

12.3.3 Delete Table

- 1 Select a database table.
- 2 Confirm with <ENTER>.

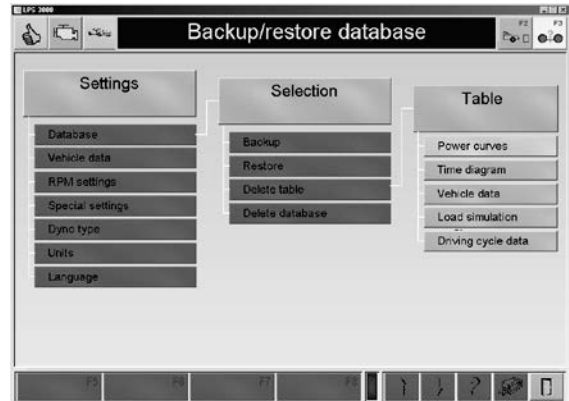

The following safety inquiry appears.

- 3 To delete the database table, select YES.
Select NO if the dataset is not to be deleted.

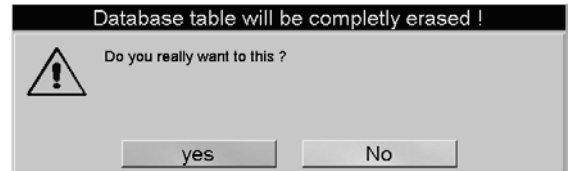

12.3.4 Delete Database

The following safety inquiry appears.

- 1 To completely delete the database, select YES
Select NO if the database is not to be deleted.

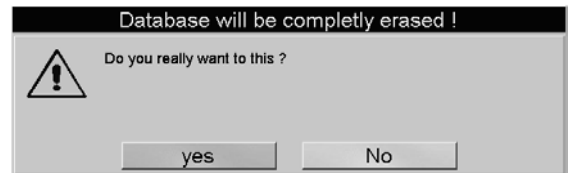

13 Maintenance

13.1 Important Information

Danger! Electric shock hazard!

- Only skilled electricians may work on electrical parts of the system!
- Before doing any maintenance work on the system disconnect it from the mains power supply and secure it against switch on!
- The maintenance work to be **by the operator** and the appropriate intervals are specified in the following chapter (this applies if no other changes have been contractually agreed upon). These kinds of maintenance work may only be done by authorized and trained personnel. Skilled personnel are those who are authorized and trained by the operator, the manufacturer and the respective service partner.
Any other maintenance, installation or repair work on the dynamometer during the warranty period may only be done by MAHA service technicians, those service partners authorized by MAHA or after consultation and approval by MAHA. The manufacturer warranty becomes invalid at non-compliance.
- Inform the operating personnel before doing maintenance work.



13.2 Annual Inspection



- The maintenance interval prescribed by the manufacturer is **12 (twelve) months**. This maintenance interval refers to normal workshop usage. If the equipment is used more frequently or under severe operating conditions (e.g. outdoors), the interval must be reduced accordingly.



- Maintenance work shall be done only by authorized and trained service technicians provided by the manufacturer, licensed dealers or service partners.
- In case of non-compliance the manufacturer's warranty becomes void.

13.3 Maintenance by the Operator

13.3.1 Roller Set

The MSR roller set should be inspected and serviced once a year or every 200 operating hours. The roller set inspection includes an inspection of all anchorings and their screws. The screwing of the cover plate is to be checked before starting the dyno.

13.3.2 Eddy Current Brake

- Grease the eddy current brake every 400 hours of operation until grease escapes at the vent pipe.



Use "SUPERTELMACO III" grease only, no mixed greases or different brands!
In case of non-compliance the bearings may be destroyed!

13.3.3 Bearing Positions

The casing bearings have a lubricating nipple which must be lubricated once a year. Amount: 1 to 2 presses from a grease gun.

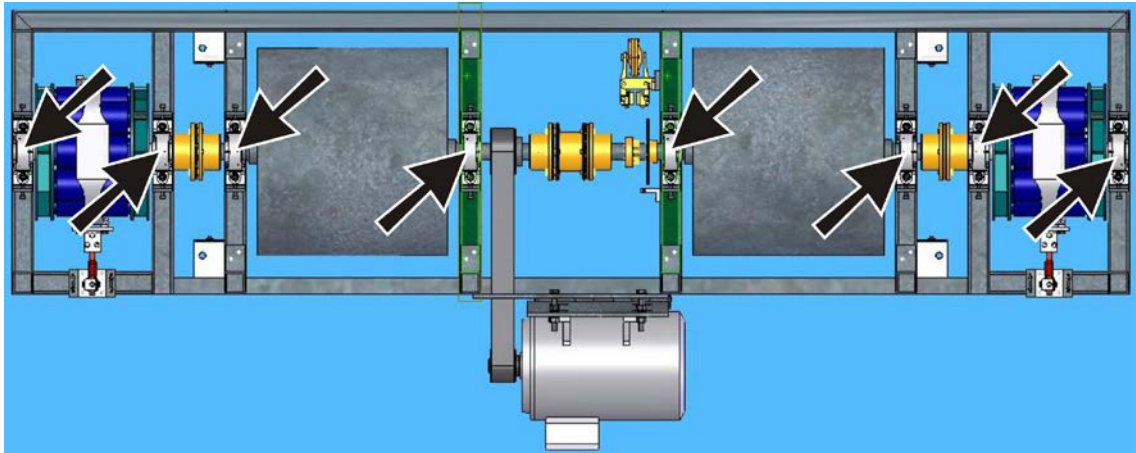

13.4 Troubleshooting

Smaller and average dyno functional malfunctions caused by wrong settings, can, in many cases be remedied on the phone in consultation with MAHA service specialists.

Ask MAHA for the daily password. This password, which is changed daily, provides you access to the service technician menu for this specific day.



When contacting MAHA by telephone, always provide the dyno serial number and the program version number and have a printed list of the softdips and variables handy, in case an error remote diagnosis is needed.

- 1 Simultaneously press <ALT> + <F12>.
- 2 With telephone error remedy provide the "Active display number".

Daily Password

- 1 Simultaneously press <ALT> + <F11>.
- 2 Enter the Daily Password. Using the password, the setting parameters in the Service Menu cannot only be viewed and printed, but also changed and saved.

13.5 Care Instructions



Regular care and maintenance is the key condition for functionality and long life expectancy of the equipment!

- Periodically clean the equipment and treat it with a care product.
- Repair damage to the paintwork immediately to prevent corrosion.
- Usage of caustic cleaning agents or high pressure and steam jet cleaners may lead to equipment damage.

13.6 Spare Parts

To ensure safe and reliable operation, only use original spare parts supplied by the equipment manufacturer.

14 Dismantling

Decommissioning and dismantling of the equipment may be done only by specially authorized and trained personnel provided by the manufacturer, licensed dealers or service partners.

15 Disposal

Pay attention to the product and safety data sheets of the lubricant used. Avoid damage to the environment. Should a disposal of the device be necessary it must be done in adherence with locally applicable legal regulations regarding environmental protection. Remove all materials properly sorted out and bring them to a suitable waste disposal service. Collect operating materials such as grease, oils, coolant, solvent-based cleaning fluids etc. in suitable containers and dispose of in an environmentally protective manner.

Alternatively, you may take the equipment to a specialised waste management plant to ensure that all components and operating liquids are properly disposed of.

16 Diagnosis of SINAMICS Components

16.1 LEDs after the Control Unit has booted

LED	Color	Status	Description, Cause	Remedy
RDY (READY)	-	Off	Electronics power supply is missing or outside permissible tolerance range.	-
	Green	Steady light	The module is ready for operation and cyclic DRIVE-CLiQ communication is taking place.	-
		Flashing 2 Hz	Writing to CompactFlash card.	-
	Red	Steady light	At least one fault is present in this module.	Remedy and acknowledge fault
		Flashing 0.5 Hz	Boot error.	Check whether CompactFlash card is plugged in correctly Replace CompactFlash card Replace Control Unit Carry-out a POWER ON
	Green / Red	Flashing 0.5 Hz	Control Unit 320 is ready. No software licenses.	Obtain licenses
	Orange	Steady light	DRIVE-CLiQ communication is being established.	-
		Flashing 0.5 Hz	Unable to load firmware to RAM.	Check whether CompactFlash card is plugged in correctly Replace CompactFlash card Replace Control Unit Carry-out a POWER ON
		Flashing 2 Hz	Firmware CRC error.	Check whether CompactFlash card is plugged in correctly Replace CompactFlash card Replace Control Unit Carry-out a POWER ON

LED	Color	Status	Description, Cause	Remedy
DP1 PROFIdrive cyclic operation	-	Off	Cyclic communication has not (yet) taken place. Note: PROFIdrive is ready for communication when the Control Unit is ready (see LED RDY).	-
	Green	Steady light	Cyclic communication is taking place.	-
		Flashing 0.5 Hz	Full cyclic communication is not yet taking place. Possible causes: <ul style="list-style-type: none"> The controller is not transmitting set-points. During isochronous operation, not global control (GC) or a faulty global control (GC) is transferred by the Controller. 	-
	Red	Steady light	Cyclic communication has been interrupted.	Remedy fault
OPT (OPTION)	-	Off	Electronics power supply is missing or outside permissible tolerance range. Module is not ready. Option board not installed or no associated drive object has been created.	-
	Green	Steady light	Option board is ready.	-
		Flashing 0.5 Hz	Depends on the option board used.	-
	Red	Steady light	At least one fault is present in this module. Option board not ready (e.g. after power-on).	Remedy and acknowledge fault
MOD	-	Off	Reserved	-

16.2 Smart Line Module 16kW and 36kW

Status		Description, Cause	Remedy
Ready (H200)	DC link (H201)		
Off	Off	Electronics power supply is missing or outside permissible tolerance range.	-
Green	Off	The component is ready for operation and cyclic DRIVE-CLiQ communication is taking place.	-
	Orange	The component is ready for operation and cyclic DRIVE-CLiQ communication is taking place. The DC link voltage is present.	-
	Red	The component is ready for operation and cyclic DRIVE-CLiQ communication is taking place. The DC link voltage is too high.	Check supply voltage
Orange	Orange	DRIVE-CLiQ communication is being established.	-
Red	-	At least one fault is present in this component. <u>Note:</u> LED is driven irrespective of the corresponding messages being reconfigured.	Remedy and acknowledge fault
Green / Red	-	Firmware is being downloaded.	-
Green / Orange or Red / Orange	-	Component recognition via LED is activated (Ip0124). <u>Note:</u> Both options depend on the LED status when component recognition is activated via p0124 = 1.	-



Hazard DC link voltages may be present at any time regardless of the status of the "DC link" LED.
The warning information on the components must be carefully observed!

16.3 Single Motor Module / Double Motor Module

Status		Description, Cause	Remedy
Ready (H200)	DC link (H201)		
Off	Off	Electronics power supply is missing or outside permissible tolerance range.	-
Green	Off	The component is ready for operation and cyclic DRIVE-CLiQ communication is taking place.	-
	Orange	The component is ready for operation and cyclic DRIVE-CLiQ communication is taking place. The DC link voltage is present.	-
	Red	The component is ready for operation and cyclic DRIVE-CLiQ communication is taking place. The DC link voltage is too high.	Check supply voltage
Orange	Orange	DRIVE-CLiQ communication is being established.	-
Red	-	At least one fault is present in this component. <u>Note:</u> LED is driven irrespective of the corresponding messages being reconfigured.	Remedy and acknowledge fault
Green / Red	-	Firmware is being downloaded.	-
Green / Orange or Red / Orange	-	Component recognition via LED is activated (Ip0124). <u>Note:</u> Both options depend on the LED status when component recognition is activated via p0124 = 1.	-



Hazard DC link voltages may be present at any time regardless of the status of the "DC link" LED.
The warning information on the components must be carefully observed!

16.4 Sensor Module Cabinet 30 (SMC30)

LED	Color	Status	Description, Cause	Remedy
RDY READY	-	Off	Electronics power supply is missing or outside permissible tolerance range.	-
	Green	Steady light	The component is ready for operation and cyclic DRIVE-CLiQ communication is taking place.	-
	Orange	Steady light	DRIVE-CLiQ communication is being established.	-
	Red	Steady light	At least one fault is present in this component. <u>Note:</u> LED is driven irrespective of the corresponding messages being reconfigured.	Remedy and acknowledge fault
	Green / Red	Flashing	Firmware is being downloaded.	-
	Green / Orange or Red / Orange	Flashing	Component recognition via LED is activated (p0144). <u>Note:</u> Both options depend on the LED status when component recognition is activated via p0144 = 1.	-
OUT > 5V	-	Off	Electronics power supply is missing or outside permissible tolerance range. Power supply > 5 V.	-
	Orange	Steady light	Electronics power supply for measuring system available. Power supply > 5 V. <u>Notice:</u> You must ensure that the connected encoder can be operated with a 24 V supply. If an encoder that is designed for a 5 V supply is operated with a 24 V supply, this can destroy the encoder electronics.	-

17 Company Information

© MAHA Maschinenbau Haldenwang GmbH & Co. KG

Legal notice based on ISO 16016:

The reproduction, distribution and utilization of this document as well as the communication of its contents to others without explicit authorization is prohibited. Offenders will be held liable for the payment of damages. All rights reserved in the event of the grant of a patent, utility model or design.

The contents of this edition have been checked with great care. However, errors cannot be fully excluded. Subject to technical change without notice.

Document

Document No.: BA053101-en
Approval Date: 2015-02-02

Manufacturer

MAHA Maschinenbau Haldenwang GmbH & Co. KG
Hoyen 20
87490 Haldenwang
Germany

Phone: +49 8374 585 0
Fax: +49 8374 585 590
Fax Parts: +49 8374 585 565
Internet: <http://www.maha.de>
E-Mail: maha@maha.de
Hotline: +49 180 66242 60 for Brake Testers and Test Lanes
+49 180 66242 80 for Automotive Lifts
+49 180 66242 90 for Dynamometers and Emission Testers

Service

AutomoTec GmbH
Maybachstraße 8
87437 Kempten
Germany
Phone: +49 180 66242 50
Fax: +49 180 66242 55
Internet: <http://www.automo-tec.com>
E-Mail: service@automo-tec.com